



QUICK SELECTION / Selezione veloce

input speed (n_1) = 1400 min⁻¹

Output Speed n_2 [min ⁻¹]	Ratio i	Motor power P_{1M} [kW]	Output torque M_{2M} [Nm]	Service factor f.s.	Nominal power P_{1R} [kW]	Nominal torque M_{2R} [Nm]	Available B5 motor flanges				Available B14 motor flanges			Output Shaft 	Ratios code
							-B	-C	-D	-E	-Q	-R	-T		
							63	71*	80*	90*	71	80	90		
407	3.44	1.5	34	1.0	1.6	35	B				C	C		2821	01
327	4.28	1.5	42	1.0	1.4	40	B				C	C		2818	02
257	5.45	1.5	53	1.0	1.5	52	B				C	C		2815	03
225	6.23	1.5	61	1.1	1.7	70	B				C	C		1921	04
194	7.20	1.5	71	1.0	1.5	70	B				C	C		2812	05
181	7.74	1.5	76	1.1	1.6	80	B				C	C		1918	06
142	9.85	1.5	97	1.0	1.5	95	B				C	C		1915	07
123	11.42	1.5	112	1.0	1.5	115	B				C	C		1715	08
107	13.03	1.1	93	1.2	1.3	114	B				C	C		1912	09
93	15.10	1.1	108	1.1	1.2	114	B				C	C		1712	10
86	16.20	0.75	80	1.3	1.0	107	B				C	C		1910	11
75	18.78	0.75	92	1.2	0.87	107	B				C	C		1710	12
66	21.15	0.75	104	1.1	0.82	114	B				C	C		1312	13
64	21.84	0.75	107	1.1	0.83	119	B				C	C		1015	14
53	26.31	0.55	95	1.1	0.62	107	B				C	C		1310	15
48.5	28.88	0.55	105	1.1	0.60	114	B				C	C		1012	16
39	35.91	0.37	87	1.2	0.46	107	B				C	C		1010	17
37.1	37.69	0.37	91	1.1	0.41	102	B				C	C		912	18
29.9	46.87	0.37	113	0.9	0.35	107	B				C	C		910	19
28.1	49.76	0.25	81	1.2	0.31	101	B				C	C		712	20
22.6	61.89	0.25	101	1.1	0.26	107	B				C	C		710	21

The dynamic efficiency is **0.96** for all ratios

*Nel montaggio P la flangia può superare l'ingombro massimo dei piedi. Eventualmente utilizzare la flangia B14
* In the P mounting the B5 motor flange can exceed the foot maximum dimensions. Possibly use the flange B14

A) Motor Flanges Available
Flange Motore Disponibili

B) Supplied with Reduction Bushing
Fornito con Bussola di Riduzione

C) Available on Request without reduction bushing
Disponibile a Richiesta senza Bussola di Riduzione

D) Motor Flange Holes Position
Posizione Fori Flangia Motore

EN Unit **302A** is supplied with synthetic oil for lifetime lubrication, no maintenance is necessary. See table 1 for lubrication and recommended quantity. In table 2 please see possible radial loads and axial loads on the gearbox.

I Il riduttore **302A** viene fornito completo di olio sintetico per la lubrificazione permanente e non necessita di alcuna manutenzione. Vedi tab.1 per oli e quantità consigliati. In tab.2 sono presenti i carichi radiali e assiali applicabili al riduttore.

D Das Getriebe **302A** ist mit synthetischem Öl gefüllt und ist lebensdauergeschmiert. In Tabelle 1 ist die Schmiermenge und das empfohlene Schmiermittel angegeben. In Tabelle 2 sind die zulässigen Radial - und Axialbelastungen des Getriebes aufgeführt.

F Le réducteur **302A** est fourni complet avec de l'huile synthétique pour la lubrification permanente et ne nécessite aucun entretien. Voir tableau 1 concernant les huiles et les quantités conseillées. Les charges radiales et axiales applicables au réducteur sont précisées dans le tableau 2.

E El reductor tamaño **302A** se suministra, lubricado de por vida con aceite sintético y no requieren mantenimiento alguna. Ver tabla 1, para cantidades y aceites recomendados. En la tabla 2, se encuentran las cargas radiales y axiales admitidas por el reductor.

LUBRICATION 302A Oil Quantity 0.15 Lt.

SHELL Omala S4 WE 320

AGIP Telium VSF 320

For all details on lubrication and plugs check our website

tab. 1

Per maggiori dettagli su lubrificazione e tappi olio vedi il nostro sito web

RADIAL AND AXIAL LOADS

Output shaft

Albero di uscita

$$F_{eq} = F_R \cdot \frac{35.7}{X+20.7}$$

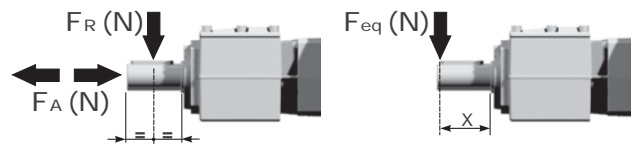

n_2	FA	FR	n_2	FA	FR	n_2	FA	FR
300	140	700	140	246	1320	70	340	1700
250	151	756	120	270	1350	40	380	1900
200	185	924	85	300	1500	15	-	-

Input shaft

Albero in entrata



n_1	FA	FR
1400	226	1130
900	264	1320
500	322	1610

tab. 2

Gearbox weight **3.5 kg**
peso riduttore With flange
With feet **4.0 Kg**

P302A **B1**... With feet
Con piedini

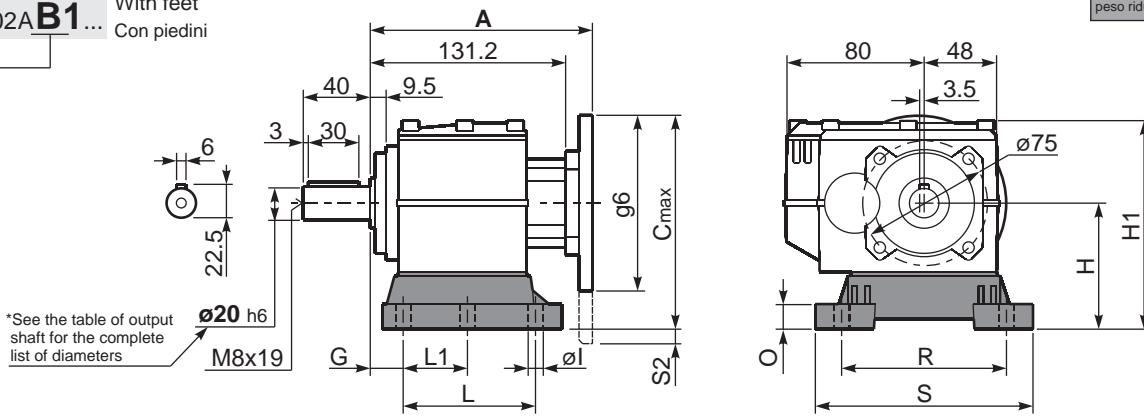

*See the table of output shaft for the complete list of diameters

Feet Code	Market reference	G	H	R	L	L1	S	H1	O	ø1	S2 only with motor flange	B5 max. Flange	kit code
B1	112	18	85	110	87	50	130	133	15	9	15 80/90B5	-	KC30.9.022
B2	212/3	18	100	130	107.5	60	155	145	5	11	3.5 80/90B5	-	KC30.9.023LM
S1	17-32	18	75	110	110	50	130	123	15	9	5 71B5	71B5	KC30.9.024

Other feet are available, see our web site
Sono disponibili altri piedini, consulta il nostro sito web

A see on page bottom

Most popular types
Tipi più diffusi

P302A-**F**... Output flanges
flange di uscita

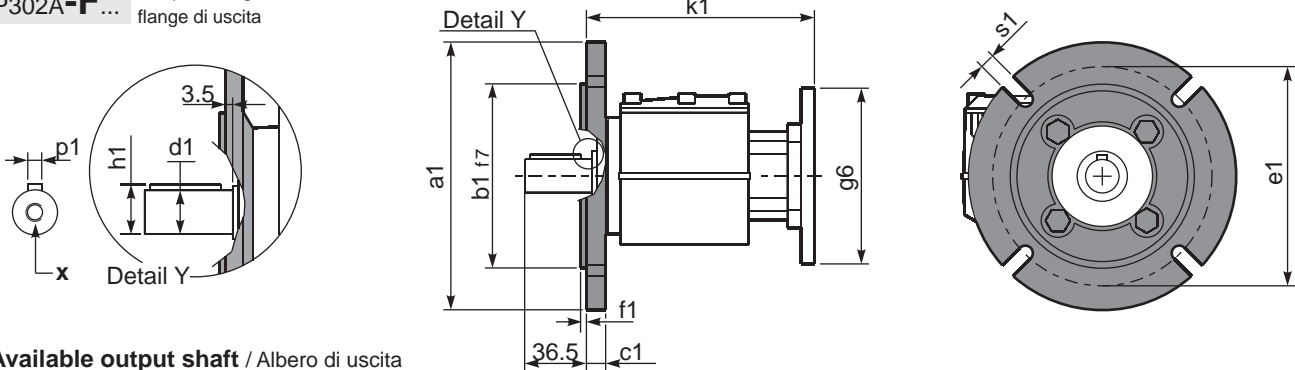

*Available output shaft / Albero di uscita

	Shaft - d1	p1	h1	x
Standard	ø 20x40	6	22.5	M8x19
On request A richiesta	ø 14x30	5	16	M6x16
	ø 16x40	5	18	M6x16
	ø 19x40	6	21.5	M6x16
	ø 24x50	8	27	M8x19
	ø 25x50	8	28	M8x19

Available output flanges / flange di uscita

a1 ø	b1	c1	e1	f1	s1	kit code
120	80	11.5	100	3	9*	KC30.9.010
140	95	11.5	115	3	9	KC30.9.011
160	110	11.5	130	3.5	9	KC30.9.012
200	130	11.5	165	3.5	11	KC30.9.013

* Holes position
Posizione fori

With flange and feet only on request. Ask for compatibility

P302A-**N**... Basic gearbox
Riduttore base

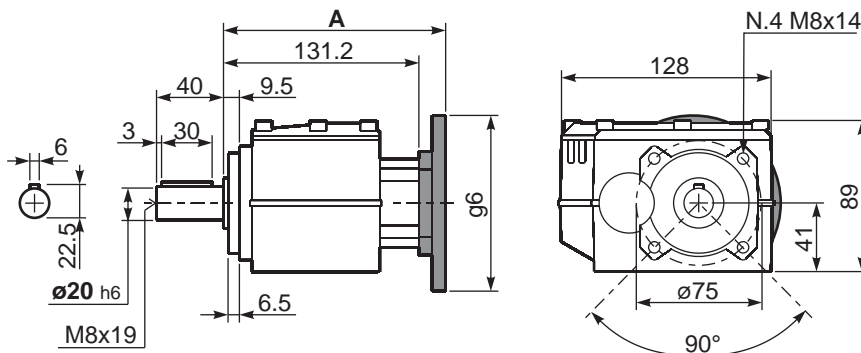

B5 Motor Flanges	A	C _{max}	g6	k1	kit code
63 B5	151.7	170	140	155.2	K063.4.041
71 B5	149.7	180	160	153.2	K063.4.042
80/90 B5	151.7	200	200	155.2	K063.4.043

R302A-**N**... Input Shaft
Albero in entrata

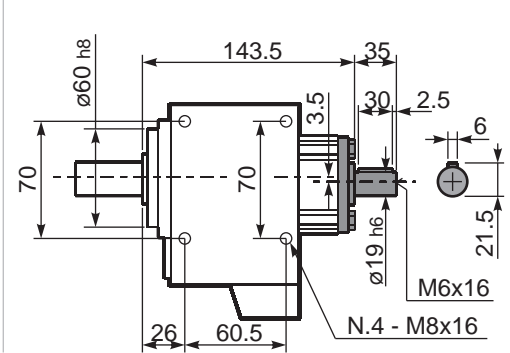

B14 Motor Flanges	A	C _{max}	g6	k1	kit code
71 B14	149.7	152.5	105	153.2	K063.4.047
80 B14	151.7	160	120	155.2	K063.4.046
90 B14	151.7	170	140	155.2	K063.4.041