



QUICK SELECTION / Selez one veloce

input speed (n₁) = 1400 min⁻¹

Output Speed n ₂ [min ⁻¹]	Ratio i	Motor power P _{1M} [kW]	Output torque M _{2M} [Nm]	Service factor f.s.	Nominal power P _{1R} [kW]	Nominal torque M _{2R} [Nm]	Available B5 motor flanges					Available B14 motor flanges				Output Shaft 	Output Shaft Ø	Ratios code
							-B	-C	-D	-E	-F	-Q	-R	-T	-U			
							63	71	80*	90*	100*	71	80	90	100			
398	3.52	3	68	1.2	3.5	80	B					C	C			2821		01
321	4.37	3	84	1.1	3.1	90	B					C	C			2818		02
252	5.56	3	107	0.9	2.7	100	B					C	C			2813		03
220	6.36	2.2	90	1.2	2.5	105	B					C	C			1921		04
191	7.33	2.2	104	1.2	2.5	120	B					C	C			2812		05
177	7.89	2.2	112	1.2	2.5	130	B					C	C			1918		06
139	10.06	2.2	143	1.2	2.5	165	B					C	C			1913		08
120	11.66	2.2	166	1.0	2.2	165	B					C	C			1713	standard	09
106	13.26	1.5	130	1.3	1.9	165	B					C	C			1912	ø25	10
102	13.68	1.5	134	1.2	1.8	165	B					C	C			1513		25
91	15.37	1.5	151	1.1	1.6	165	B					C	C			1712	ø16	11
86	16.33	1.5	160	1.0	1.5	165	B					C	C			1313	ø19	26
78	18.04	1.5	177	0.9	1.4	165	B					C	C			1512	ø20	23
65	21.54	1.1	154	1.1	1.2	165	B					C	C			1312	ø24	14
63	22.29	1.1	160	1.0	1.1	165	B					C	C			1013	On request	15
53	26.31	0.75	129	1.2	0.90	155	B					C	C			1310		16
47.6	29.40	0.75	144	1.1	0.86	165	B					C	C			1012		17
39	35.91	0.55	130	1.2	0.66	155	B					C	C			1010		18
36.5	38.37	0.55	139	1.2	0.66	165	B					C	C			912		19
29.9	46.87	0.55	170	0.9	0.51	155	B					C	C			910		20
27.6	50.67	0.37	123	1.1	0.41	137	B					C	C			712		21
22.6	61.89	0.37	150	1.0	0.38	155	B					C	C			710		22

The dynamic efficiency is **0.96** for all ratios

*Nel montaggio P la flangia può superare l'ingombro massimo dei piedi. Eventualmente utilizza re la flangia B14
* In the P mounting the B5 motor flange can exceed the foot maximum dimensions. Possibly use the flange B14

Motor Flanges Available
Flange Motore Disponibili

B) Supplied with Reduction Bushing
Fornito con Bussola di Riduz one

B) Available on Request without reduction bushing
Disponibile a Richiesta senza Bussola di Riduz one

C) Motor Flange Holes Position
Posiz one Fori Flangia Motore

EN Unit **412A** is supplied with synthetic oil for lifetime lubrication, no maintenance is necessary. See table 1 for lubrication and recommended quantity. In table 2 please see possible radial loads and axial loads on the gearbox.

I Il riduttore **412A** viene fornito completo di olio sintetico per la lubrificaz one permanente e non necessita di alcuna manutenz one. Vedi tab.1 per oli e quantit à consigliati. In tab.2 sono presenti i carichi radiali e assiali applicabili al riduttore.

D Das Getriebe **412A** ist mit synthetischem Öl gefüllt und ist lebensdauergeschmiert. In Tabelle 1 ist die Schmiermenge und das empfohlene Schmiermittel angegeben. In Tabelle 2 sind die z lässigen Radial - und Axialbelastungen des Getriebes aufgeföhrt.

F Le réducteur **412A** est fourni complet avec de l'huile synthétique pour la lubrification permanente et ne nécessite aucun entretien. Voir tableau 1 concernant les huiles et les quantités conseillées. Les charges radiales et axiales applicables au réducteur sont précisées dans le tableau 2.

E El reductor tamaño **412A** se suministra, lubricado de por vida con aceite sintético y no requieren mantenimiento alguna. Ver tabla 1, para cantidades y aceites recomendados. En la tabla 2, se encuentran las cargas radiales y axiales admitidas por el reductor.

Standard supplied	For these mounting position specify in the order or add oil Per queste posiz oni specificare in fase d'ordine o aggiungere olio						
B3	B6	B7	B8	V5	V6	V8	V8
0.25 LT	0.35 LT	0.40 LT	0.45 LT	0.40 LT	0.50 LT	Ask	Ask
SHELL Omala S4 WE 320				ENI Telium VSF 320			

For all details on lubrication and plugs check our website **tab. 1**
Per maggiori dettagli su lubrificaz one e tappi olio vedi il nostro sito web

RADIAL AND AXIAL LOADS								
Output shaft Albero di uscita			$F_{eq} = F_R \cdot \frac{46}{X+21}$					
n ₂	FA	FR	n ₂	FA	FR	n ₂	FA	FR
300	310	1550	140	406	2030	70	540	2700
250	330	1650	120	448	2240	40	600	3000
200	360	1800	85	480	2400	15	600	3000
Input shaft Albero in entrata								
n ₁	FA	FR						
1400	240	1200						
900	280	1400						
500	340	1700						

tab. 2

P412A **B1** ... With feet
Con piedini

Gearbox weight With flange **5.7 kg**
peso riduttore With feet **5.9 Kg**

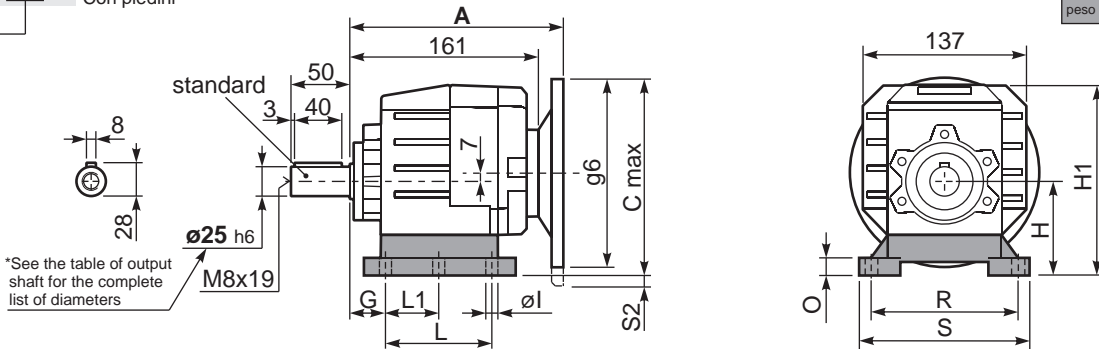

Feet / piedini

Feet Code	Market reference	G	H	R	L	L1	S	H1	O	øl	S2 only with motor flange	B5 max. Flange	kit code
B1	112	18	85	110	87	50	130	167.5	15	-	8/33 80/90B5 100/112B5	-	KC35.9.021
B2	212/3	18	100	130	107.5	60	155	182.5	17	11	18 100/112B5	-	KC40.9.025
S1	17	18	75	110	90÷110	50	145	155.5	15	9	18/43 80/90B5 100/112B5	-	KC40.9.022
S2	27	25	90	110	130	-	145	172.5	20	9	3/28 80/90B5 100/112B5	-	KC40.9.024
H2	022-223	25	100	110	115	-	145	182.5	20	9	18 100/112B5	-	KC40.9.026
M1	42/3	25	80	110÷120	85	-	145	162.5	15	9	13/38 80/90B5 100/112B5	-	KC40.9.023

Other feet are available, see our web site
Sono disponibili altri piedini, consulta il nostro sito web

A see on page bottom

Most popular types
Tipi più diffusi

P412A-**F** ... Output flanges
flange di uscita

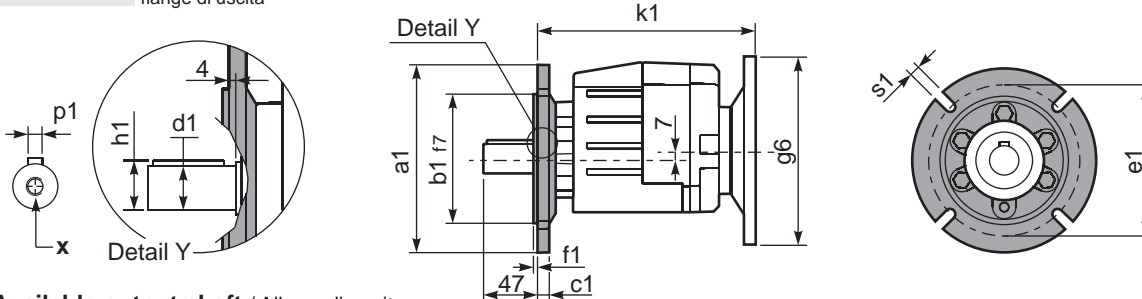

***Available output shaft / Albero di uscita**

	Shaft - d1	p1	h1	x
Standard	ø 25x50	8	28	M8x19
On request A richiesta	ø 16x40	5	18	M6x16
	ø 19x40	6	21.5	M6x16
	ø 20x40	6	22.5	M8x19
	ø 24x50	8	27	M8x19

Available output flanges / flange di uscita

a1 ø	b1	c1	e1	f1	s1	kit code
120	80	10	100	3	7	KC40.9.010
140	95	10	115	3	9	KC40.9.011
160	110	10	130	3.5	9	KC40.9.012
200	130	10	165	3.5	11	KC40.9.013
250	180	11.5	215	3.5	14	KC40.9.014

With flange and feet only on request. Ask for compatibility

P412A-**N** ... Basic gearbox
Riduttore base

R412A-N ... Input Shaft
Albero in entrata

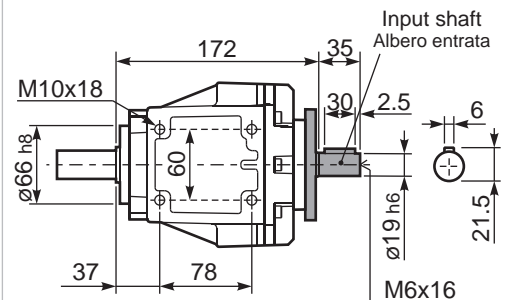
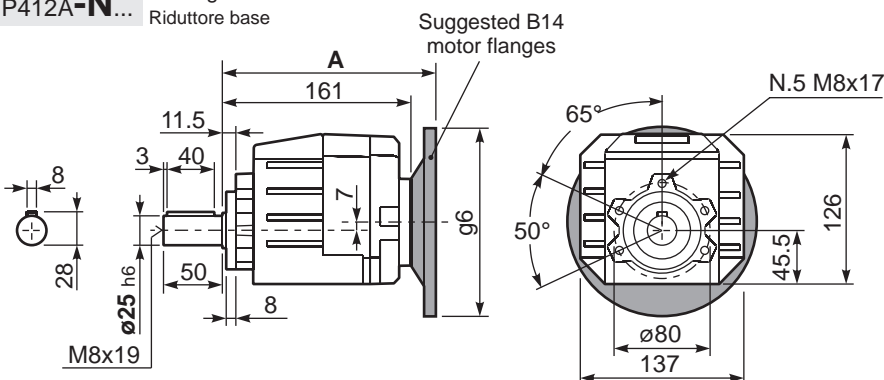

B5 Motor Flanges	A	C _{max}	g6	k1	kit code
63 B5	181.5	177	140	185.5	K063.4.041
71 B5	179.5	187	160	183.5	K063.4.042
80/90 B5	181.5	207	200	185.5	K063.4.043
100/112 B5	196.5	232	250	200.5	KC40.4.043

B14 Motor Flanges	A	C _{max}	g6	k1	kit code
71 B14	179.5	159.5	105	183.5	K063.4.047
80 B14	181.5	167	120	185.5	K063.4.046
90 B14	181.5	177	140	185.5	K063.4.041
100/112 B14	196.5	187	160	200.5	KC40.4.041