



QUICK SELECTION / Selezione veloce input speed (n_1) = 1400 min⁻¹

Output Speed n_2 [min ⁻¹]	Ratio i	Motor power P_{1M} [kW]	Output torque M_{2M} [Nm]	Service factor f.s.	Nominal power P_{1R} [kW]	Nominal torque M_{2R} [Nm]	Available B5 motor flanges					Available B14 motor flanges				Output Shaft			
							-C	-D	-E	-F	-G	-R	-T	-U	-V			Ratios code	
							71	80	90	100 112	132	80	90	100 112	132				
1077	1.30	4	34	1.2	4.6	40	B										3039	standard ø28	01
571	2.45	4	64	1.1	4.3	70	B										2049		02
423	3.31	4	87	1.0	4.1	90	B										1653		03
325	4.31	4	113	1.0	3.8	110	B										1356	04	
266	5.27	3	104	1.1	3.1	110	B										1158	On request	05
184	7.63	2.2	111	1.0	2.2	110	B										861	ø24	06
133	10.50	1.1	77	1.0	1.1	80	B										663		07

The dynamic efficiency is **0.98** for all ratios

Motor Flanges Available Flange Motore Disponibili
Supplied with Reduction Bushing Fornito con Bussola di Riduzione
Available on Request without reduction bushing Disponibile a Richiesta senza Bussola di Riduzione
Motor Flange Holes Position Posizione Fori Flangia Motore

EN Unit **511A** is supplied with synthetic oil for lifetime lubrication, no maintenance is necessary. See table 1 for lubrication and recommended quantity. In table 2 please see possible radial loads and axial loads on the gearbox.

I Il riduttore **511A** viene fornito completo di olio sintetico per la lubrificazione permanente e non necessita di alcuna manutenzione. Vedi tab.1 per oli e quantità consigliati. In tab.2 sono presenti i carichi radiali e assiali applicabili al riduttore.

D Das Getriebe **511A** ist mit synthetischem Öl gefüllt und ist lebensdauer geschmiert. In Tabelle 1 ist die Schmiermenge und das empfohlene Schmiermittel angegeben. In Tabelle 2 sind die zulässigen Radial- und Axialbelastungen des Getriebes aufgeführt.

F Le réducteur **511A** est fourni complet avec de l'huile synthétique pour la lubrification permanente et ne nécessite aucun entretien. Voir tableau 1 concernant les huiles et les quantités conseillées. Les charges radiales et axiales applicables au réducteur sont précisées dans le tableau 2.

E El reductor tamaño **511A** se suministra, lubricado de por vida con aceite sintético y no requieren mantenimiento alguna. Ver tabla 1, para cantidades y aceites recomendados. En la tabla 2, se encuentran las cargas radiales y axiales admitidas por el reductor.

LUBRICATION 511A Oil Quantity 0.29 Lt.

AGIP Telium VSF 320

SHELL Omala S4 WE 320

For all details on lubrication and plugs check our website

tab. 1

Per maggiori dettagli su lubrificazione e tappi olio vedi il nostro sito web

RADIAL AND AXIAL LOADS

Output shaft

Albero di uscita

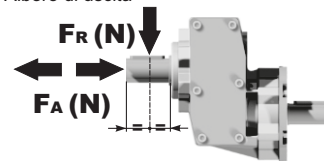

$$F_{eq} = FR \cdot \frac{47.5}{X+22.5}$$

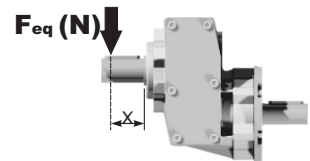

n_2	FA	FR	n_2	FA	FR	n_2	FA	FR
700	294	1470	400	370	1850	200	460	2300
600	320	1600	300	400	2000	140	510	2550

Input shaft

Albero in entrata

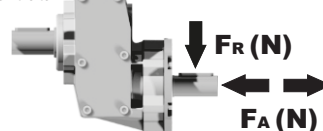

n_1	FA	FR
1400	400	2000
900	440	2200

tab. 2

P511-F... Output flanges
flange di uscita

Gearbox weight
peso riduttore **5.00 kg**

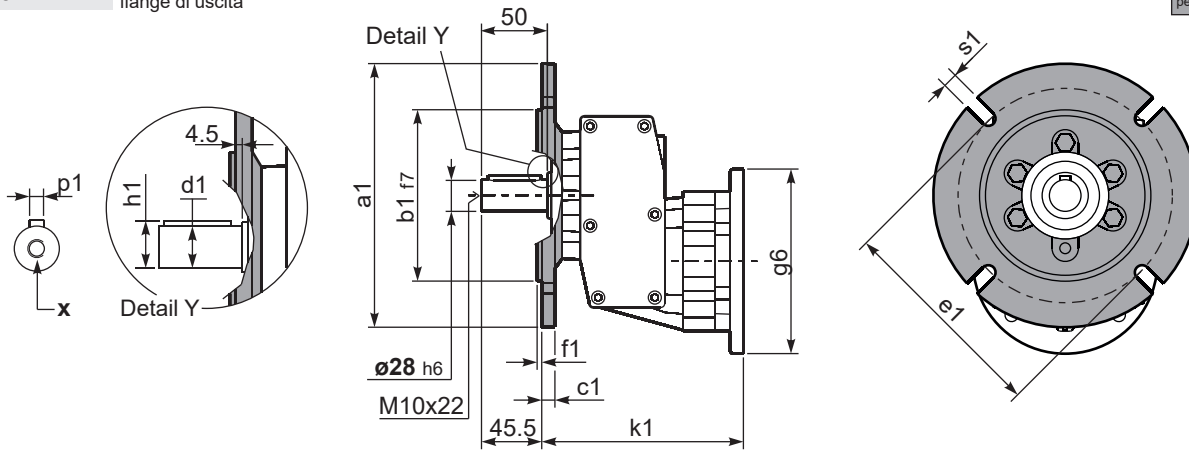

***Available output shaft / Albero di uscita**

	Shaft - d1	p1	h1	x
Standard	ø 28x50	8	31	M10x22
On request A richiesta	ø 24x50	8	27	M8x19

Available output flanges / flange di uscita

a1 ø	b1	c1	e1	f1	s1	kit code
120	80	10	100	3	7	KC40.9.010
140	95	10	115	3	9	KC40.9.011
160	110	10	130	3.5	9	KC40.9.012
200	130	11	165	3.5	11	KC40.9.013
250	180	11.5	215	3.5	14	KC40.9.014

P511A-H1. With feet
Con piedini

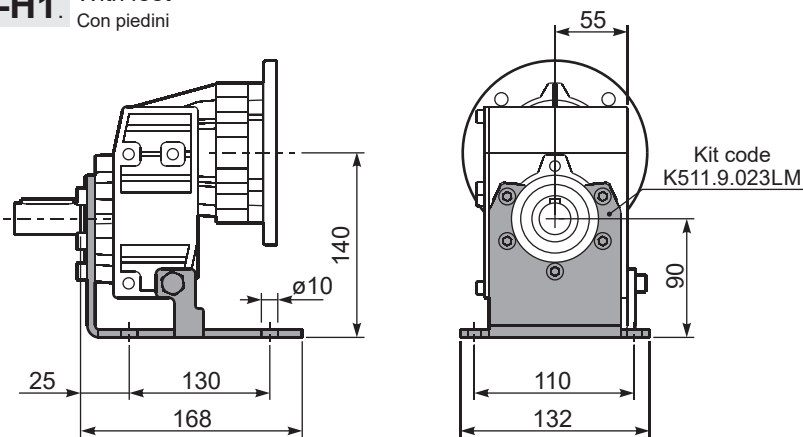

R511A-N... Input Shaft
Albero in entrata

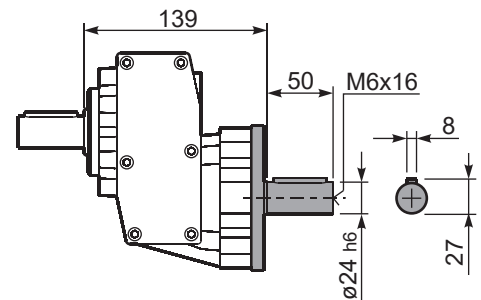

P511-N... Basic gearbox
Riduttore base

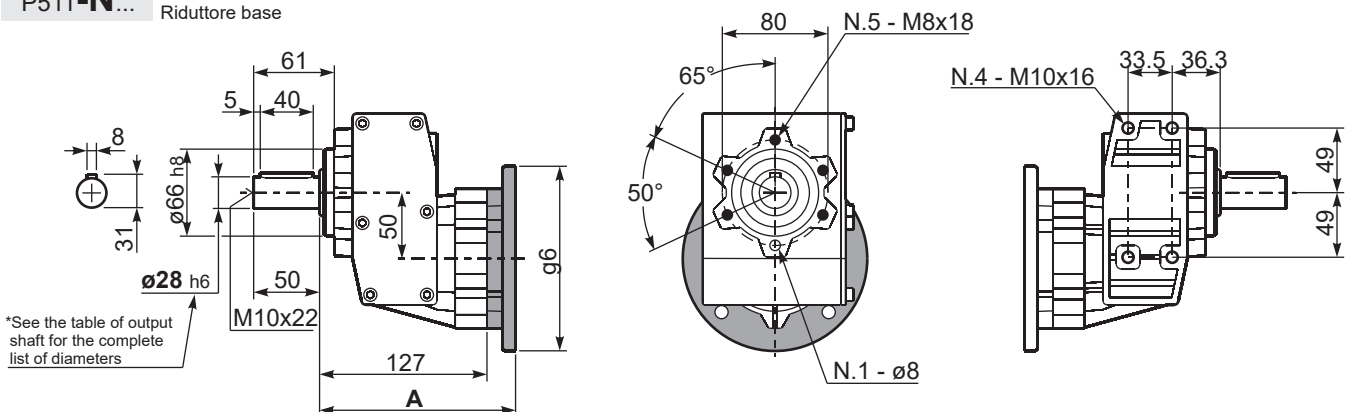

*See the table of output shaft for the complete list of diameters

B5 Motor Flanges	A	g6	k1	kit code
71 B5	145.5	160	150	K023.4.041
80/90 B5	147.5	200	152	K023.4.042
100/112 B5	156.5	250	161	K023.4.043
132 B5	177.5	300	179	KC51.4.043

B14 Motor Flanges	A	g6	k1	kit code
80 B14	147.5	120	152	K085.4.046
90 B14	147.5	140	152	K085.4.045
100/112 B14	156.5	160	161	K085.4.047
132 B14	177.5	200	179	KC51.4.041