



QUICK SELECTION / Selez one veloce

input speed (n₁) = 1400 min⁻¹

Output Speed n ₂ [min ⁻¹]	Ratio i	Motor power P _{1M} [kW]	Output torque M _{2M} [Nm]	Service factor f.s.	Nominal power P _{1R} [kW]	Nominal torque M _{2R} [Nm]	Available B5 motor flanges					Available B14 motor flanges				Output Shaft			
							-C	-D	-E	-F	-G	-R	-T	-U	-V	Ratio code	Output Shaft	Output Shaft	
							71	80	90	100 112	132*	80	90	100 112	132				
388	3.61	7.5	171	1.1	8.0	190	B										3018	standard ø35	01
331	4.23	7.5	200	1.1	8.3	230	B										3016		02
279	5.01	7.5	238	1.1	7.9	260	B										3014		03
231	6.07	7.5	288	1.1	7.8	310	B										3012		04
206	6.81	7.5	323	1.1	7.9	350	B										2018		05
176	7.96	7.5	378	1.0	7.1	370	B										2016		07
148	9.45	5.5	331	1.2	6.6	410	B										2014		08
122	11.43	5.5	401	1.1	5.7	425	B										2012		09
100	14.00	4	359	1.2	4.7	435	B										1316		10
84	16.62	4	426	1.2	4.7	515	B										1314		11
70	20.10	4	515	1.0	4.0	530	B										1312		12
57	24.61	3	475	1.1	3.3	530	B										1112		20
47.6	29.41	2.2	418	1.1	2.3	450	B										814		14
39.3	35.58	2.2	506	1.0	2.3	530	B										812		15
34.6	40.50	1.1	290	1.1	1.2	320	B										614		16
31.7	44.23	1.5	433	0.9	1.4	410	B										810		17
28.6	49.00	1.1	351	1.1	1.2	400	B										612		18
23.0	60.90	1.1	436	0.9	1.0	410	B										610		19

The dynamic efficiency is **0.96** for all ratios

*Nel montaggio P la flangia può superare l'ingombro massimo dei piedi. Eventualmente utilizza re la flangia B14
* In the P mounting the B5 motor flange can exceed the foot maximum dimensions. Possibly use the flange B14

A Motor Flanges Available
Flange Motore Disponibili

B Supplied with Reduction Bushing
Fornito con Bussola di Riduiz one

C Available on Request without reduction bushing
Disponibile a Richiesta senza Bussola di Riduiz one

D Motor Flange Holes Position
Posiz one Fori Flangia Motore

EN Unit **612A** is supplied with synthetic oil for lifetime lubrication, no maintenance is necessary.
See table 1 for lubrication and recommended quantity.
In table 2 please see possible radial loads and axial loads on the gearbox.

I Il riduttore **612A** viene fornito completo di olio sintetico per la lubrificaz one permanente e non necessita di alcuna manutenz one.
Vedi tab.1 per oli e quantit  consigliati.
In tab.2 sono presenti i carichi radiali e assiali applicabili al riduttore.

D Das Getriebe **612A** ist mit synthetischem   gef llt und ist lebensdauer geschmiert.
In Tabelle 1 ist die Schmiermenge und das empfohlene Schmiermittel angegeben.
In Tabelle 2 sind die m   l ssigen Radial - und Axialbelastungen des Getriebes aufgef hrt.

F Le r ducteur **612A** est fourni complet avec de l'huile synth tique pour la lubrification permanente et ne n cessite aucun entretien.
Voir tableau 1 concernant les huiles et les quantit s conseill es.
Les charges radiales et axiales applicables au r ducteur sont pr cis es dans le tableau 2.

E El reductor tama o **612A** se suministra, lubricado de por vida con aceite sint tico y no requieren mantenimiento alguna.
Ver tabla 1, para cantidades y aceites recomendados.
En la tabla 2, se encuentran las cargas radiales y axiales admitidas por el reductor.

Standard supplied	For these mounting position specify in the order or add oil						
	Per queste posiz one specificare in fase d'ordine o aggiungere olio						
0.80 LT	1.00 LT	1.20 LT	1.20 LT	1.30 LT	1.35 LT	1.35 LT	Ask
SHELL Omala S4 WE 320				ENI Telium VSF 320			

For all details on lubrication and plugs check our website **tab. 1**
Per maggiori dettagli su lubrificaz one e tappi olio vedi il nostro sito web

RADIAL AND AXIAL LOADS									
Output shaft Albero di uscita					Feq = Fr · $\frac{60.5}{X+25.5}$				
n ₂	FA	FR	n ₂	FA	FR	n ₂	FA	FR	
300	560	2800	140	740	3700	70	890	4200	
250	600	3000	120	760	3800	40	1160	5800	
200	640	3200	85	840	4000	15	1300	6500	
Input shaft Albero in entrata									
n ₁	FA	FR							
1400	450	2250							
900	500	2500							
500	600	3000							

tab. 2

P612A **B1** ... With feet
Con piedini

Gearbox weight With flange **14.1 kg**
peso riduttore With feet **14.5 kg**

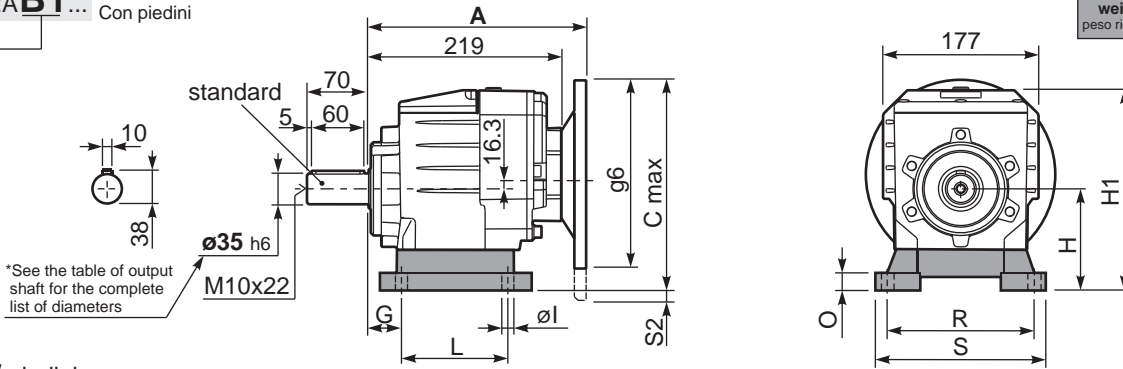

Feet / piedini

Feet Code	Market reference	G	H	R	L	S	H1	O	øl	S2 only with motor flange	B5 max. Flange	kit code
B4	412/3	20	130	180	149.5	216	242	18	14	-	-	KC60.9.024
S4	47-57	30	115	135	165	170	227	25	14	13 132B5	-	KC50.9.022
M3	62/3	35	120	170-185	110	230	232	20	14	8 132B5	-	KC60.9.023
S7	77	35	140	170	205	204	252	8	14	-	-	KC60.9.029LM
H4	024-243	35	155	170	150	225	267	30	14	-	-	KC60.9.025

Other feet are available, see our web site
Sono disponibili altri piedini, consulta il nostro sito web

A see on page bottom

Most popular types
Tipi più diffusi

P612A-**F**... Output flanges
flange di uscita

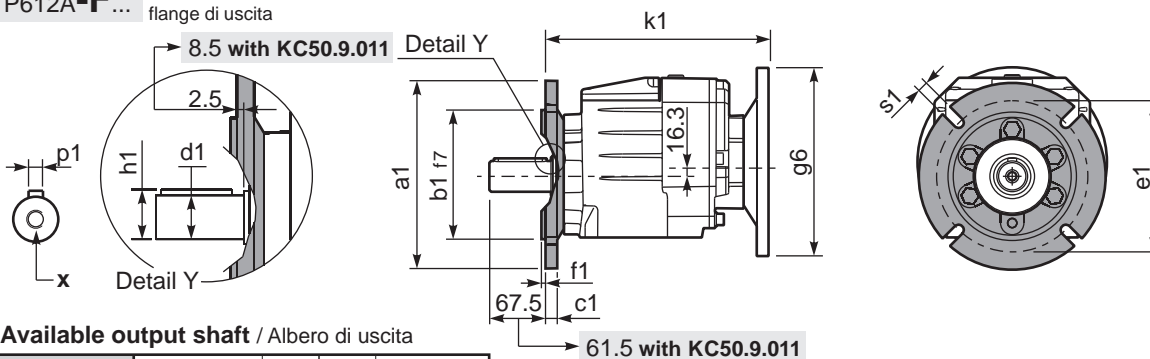

*Available output shaft / Alberi di uscita

	Shaft - d1	p1	h1	x
Standard	ø 35x70	10	38	M10x22
On request A richiesta	ø 28x60	8	31	M8x20
	ø 30x60	8	33	M10x22
	ø 38x70	10	41	M10x25
	ø 40x80	12	43	M12x28

Available output flanges / flange di uscita

a1 ø	b1	c1	e1	f1	s1	kit code
160	110	14	130	3.5	11	KC50.9.011
200	130	13	164	3.5	11	KC50.9.012
250	180	15.5	215	4	14	KC50.9.013

With flange and feet only on request.
Ask for compatibility

P612A-**N**... Basic gearbox
Riduttore base

R612A-N... Input Shaft
Albero in entrata

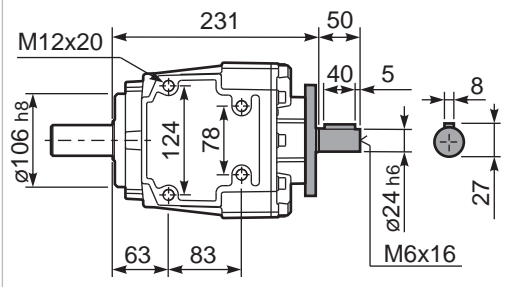
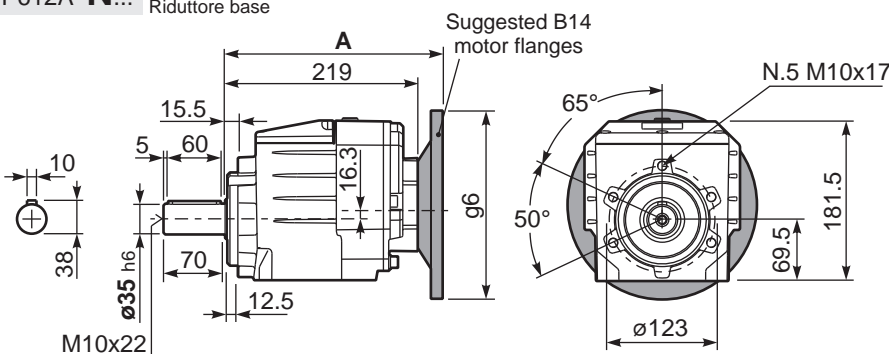

B5 Motor Flanges	A	C _{max}	g6	k1	kit code	k1 with KC50.9.011	B14 Motor Flanges	A	C _{max}	g6	k1	kit code	k1 with KC50.9.011
71 B5	237.5	251.3	160	240	K023.4.041	246	80 B14	239.5	231.3	120	242	K085.4.046	248
80/90 B5	239.5	271.3	200	242	K023.4.042	248	90 B14	239.5	241.3	140	242	K085.4.045	248
100/112 B5	248.5	296.3	250	251	K023.4.043	257	100/112 B14	248.5	251.3	160	251	K085.4.047	257
132 B5	269.5	321.3	300	269	KC51.4.043	275	132 B14	269.5	271.3	200	269	KC51.4.041	275