

DIAGRAMMI - CURVES - COURBES

"PTS.. 65" - "PTSex.. 65"

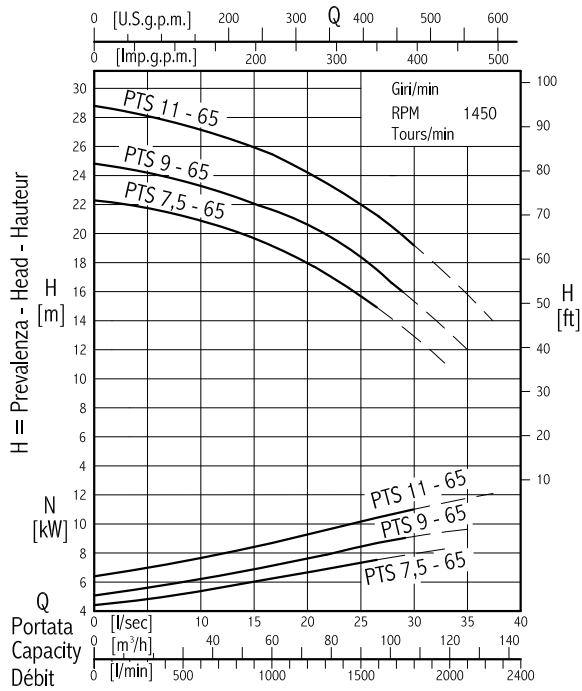

"PTS.. 80" - "PTSex.. 80" - "PTS.. 80N" - "PTSex.. 80N"

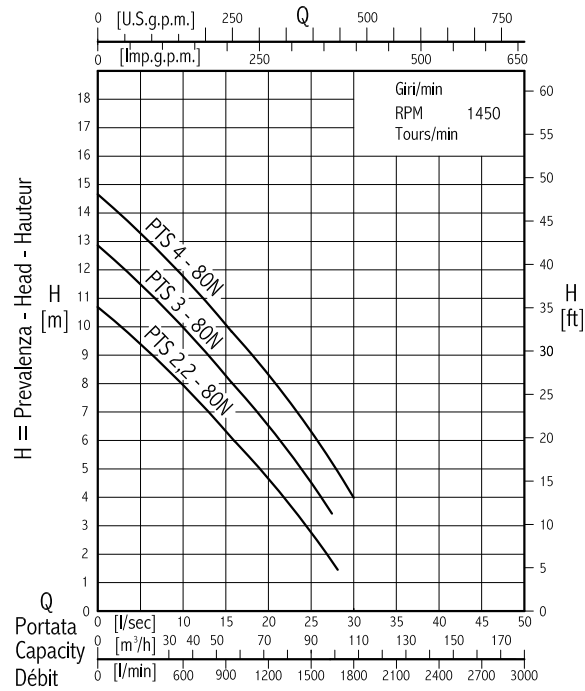

Potenza assorbita [kW]
N = Absorbed power [kW]
Puissance absorbée [kW]

Curve per liquidi aventi densità 1 - viscosità 1 mm²/s - alla temperatura di 20° C.
Curves tested on liquid density 1 - viscosity 1 mm²/s - temperature 20° C.
Courbes établies pour liquides densité 1 - viscosité 1 mm²/s - température 20° C.

"PTS.. 80" - "PTSex.. 80" - "PTS.. 80N" - "PTSex.. 80N"

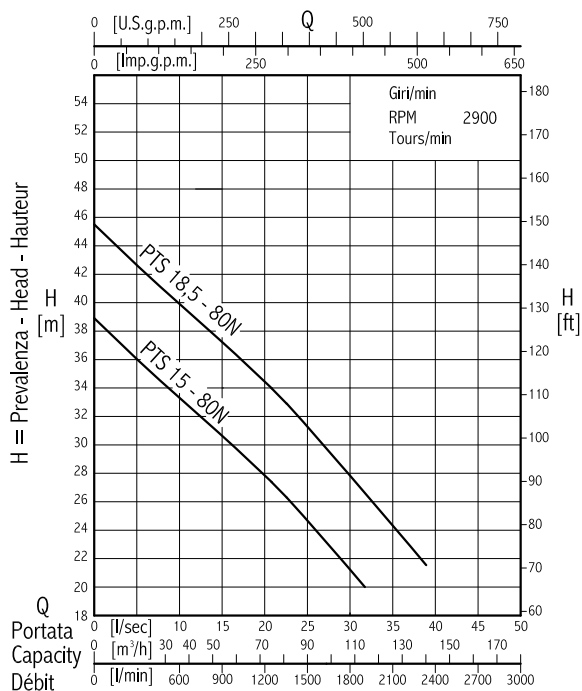

"PTS.. 100" - "PTSex.. 100"

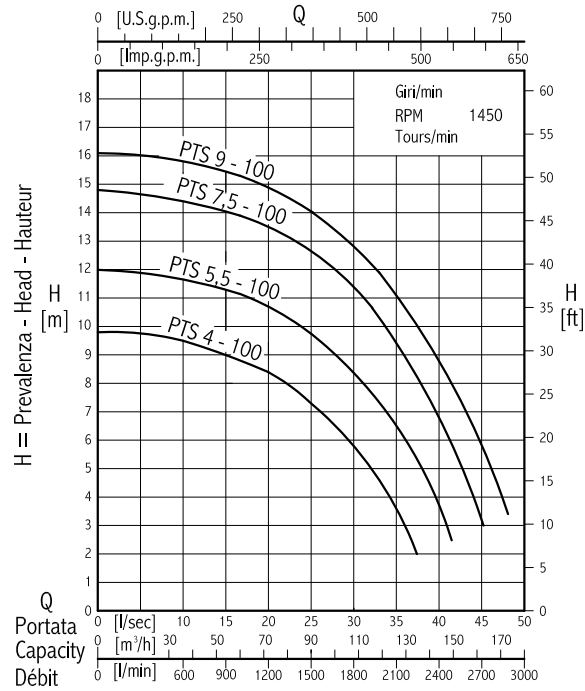

CARATTERISTICHE STANDARD

Motori elettrici asincroni trifase con rotore a gabbia di scoiattolo.
N°2 sonde termiche inserite nell'avvolgimento statorico.
Grado di protezione "IP 68".
Isolamento classe "F".
Max profondità immersione 20 m.
Max contenuto sostanze solide in sospensione 12%, esclusi i modelli PTS 65 e 100K, a contenuto max 8%.
Cavo sommergibile in neoprene H07-RN-F.
pH liquido 5 ÷ 12.
Max temperatura del liquido pompato 40°C.
Servizio continuo.

STANDARD FEATURES

Asynchronous three phase electric motors with squirrel cage rotor.
N.2 thermic probes installed in the stator winding.
Protection "IP 68".
"F" class insulation.
Max submergence depth: 20 m.
Max solid content in the liquid: 12%, PTS 65 and 100K excluded, max solid content 8%.
Submersible H07-RN-F neoprene cable.
Liquids pH 5 - 12.
Max temperature of pumped liquid: 40°C.
Continuous service.

CARACTERISTIQUES STANDARD

Moteurs électriques asynchrones triphasés, rotor à cage d'écuriel.
N°2 sondes thermiques incorporées dans l'enroulement du stator.
Degré de protection "IP 68".
Isolement classe "F".
Max profondeur d'immersion 20 m.
Max contenu de substances solides en suspension 12%, modèles PTS 65 et 100K exdu, max contenu 8%.
Max pH du liquide 5 ÷ 12.
Câble immergé en néoprène H07-RN-F.
Max température du liquide pompé 40°C.
Service continu.

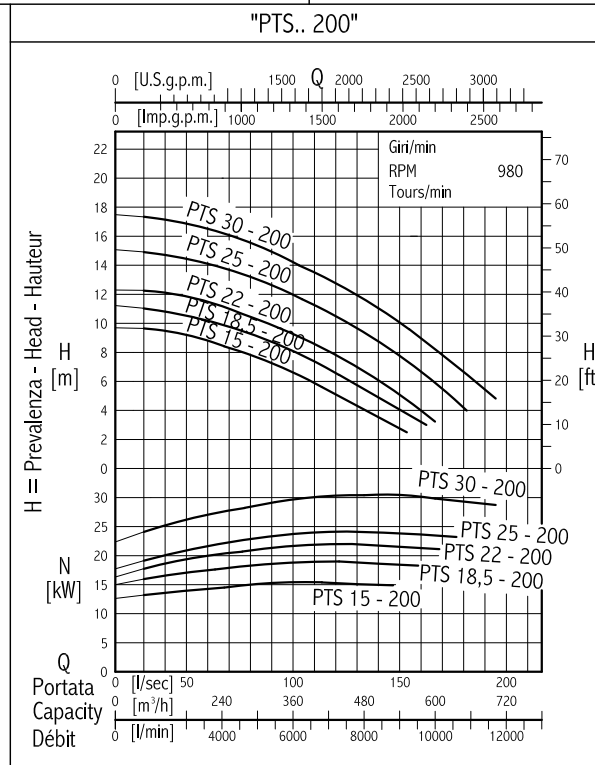
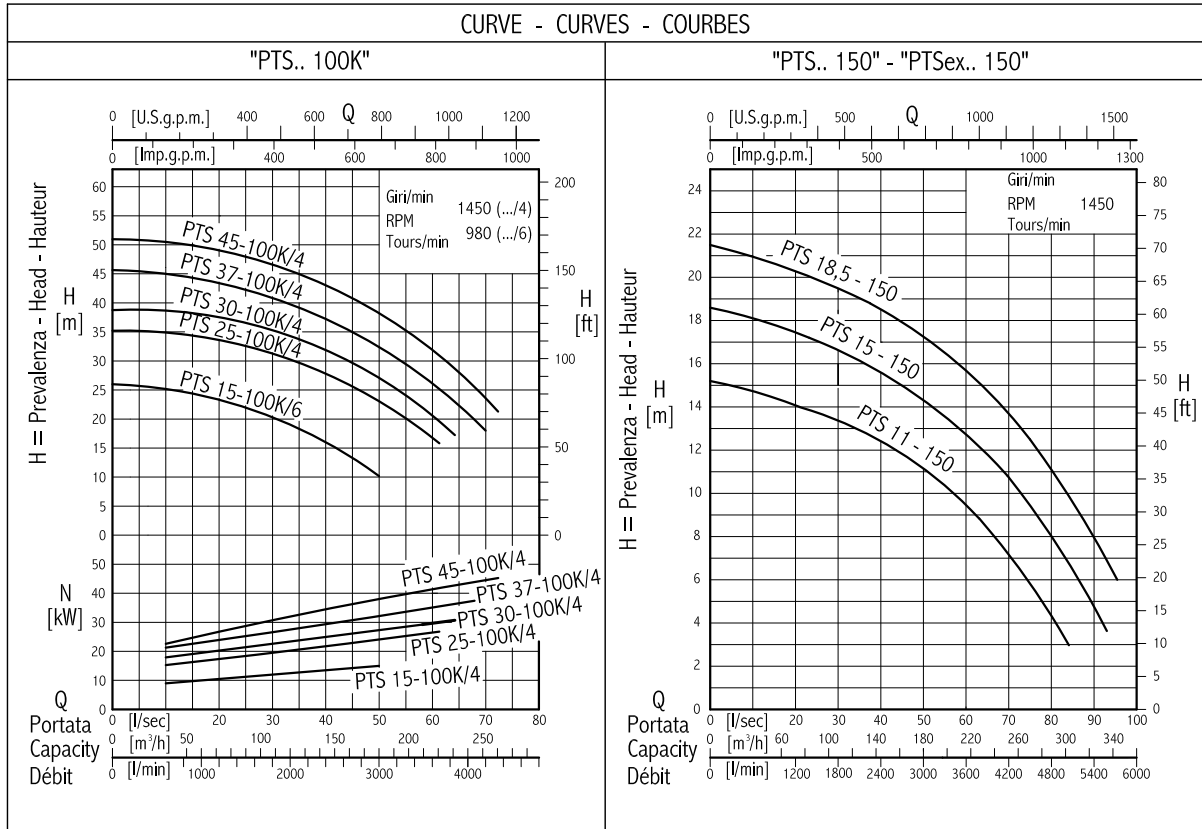

Curve per liquidi aventi densità 1 - viscosità 1 mm²/s - alla temperatura di 20° C.
Curves tested on liquid density 1 - viscosity 1 mm²/s - temperature 20° C.
Courbes établies pour liquides densité 1 - viscosité 1 mm²/s - température 20° C.

Potenza assorbita [kW]
N = Absorbed power [kW]
Puissance absorbée [kW]

CARATTERISTICHE OPZIONALI

Le pompe sommergibili serie PTS-65/80/80N/100/150 possono essere fornite a richiesta di uno speciale rivestimento anticorrosione al Nichel su tutta la superficie della pompa a contatto con liquidi aventi pH particolarmente aggressivo (suffisso "NC") o parzialmente sulla sola parte trituratrice (suffisso "NP").

OPTIONAL FEATURES

Submersible pumps PTS-65/80/80N/100/150 series can be equipped, on demand, with a special chemical Nickel coating that protects the surface in contact with aggressive liquids. This treatment can be applied on the complete pump ("NT" version), or only on the cutting system ("NP" version).

OPTIONS

Les pompes série PTS-65/80/80N/100/150 sont disponibles, sur demande, avec un revêtement chimique spécial en Nickel résistant à la corrosion provoquée par les liquides agressifs. On peut appliquer le revêtement sur toute la pompe (version «NT»), ou seulement sur la partie dilacératrice ("NP" version).

CARATTERISTICHE MOTORI TRIFASE - 50 Hz- 400 V ±10% 50 Hz - THREE-PHASE- MOTOR FEATURES - 400 V ±10% CARACTERISTIQUES DES MOTEURS TRIPHASES - 50 Hz- 400 V ±10%									
Elettropompa tipo Electric pump type Electropompe type	Potenza motore Motor rating Puissance moteur	Avvolgimenti Windings Bobinages	Assorbimento Absorption Intensité	Giri/min RPM T/min	CAVO ALIMENTAZIONE - FEEDING CABLE - CABLE D'ALIMENTATION			AVVIAMENTO	
					N° cavi N° cables N° câbles	N° conduttori cavo x sezione N° of wires x size N° conducteurs câble à section	Lunghezza cavo Cable length Longueur câble	Diretto Direct Direct	△-△
	[kW]	[V]	[A (400V)]	n	n°	[mm ²]	[m]		
PTS 7,5 - 65	7,5	400-690	15,8	1440	1	9 x 2,5	10	△	△-△
PTSex 7,5 - 65									
PTS 9 - 65	9		19	1440				9 x 4	△
PTSex 9 - 65									
PTS 11 - 65	11		23,5	1450		9 x 4		△	△-△
PTSex 11 - 65									
PTS 2,2 - 80	2,2	230-400	5,3	1420		△			
PTS 2,2 - 80N									
PTSex 2,2 - 80									
PTSex 2,2 - 80N									
PTS 3 - 80	3		6,4	1420	9 x 1,5	△			
PTS 3 - 80N									
PTSex 3 - 80									
PTSex 3 - 80N									
PTS 4 - 80	4	9,1	1405	1405	△	△-△			
PTS 4 - 80N									
PTSex 4 - 80									
PTSex 4 - 80N									
PTS 15 - 80	15	31,2	2920	2920	△	△-△			
PTS 15 - 80N									
PTS 15ex - 80									
PTS 15ex - 80N									
PTS 18,5 - 80	18,5	36,5	2930	2930	△	△-△			
PTS 18,5 - 80N									
PTSex 18,5 - 80									
PTSex 18,5 - 80N									
PTS 4 - 100	4	9,1	1405	1405	△	△-△			
PTSex 4 - 100									
PTS 5,5 - 100	5,5	12,5	1430	1430	△	△-△			
PTSex 5,5 - 100									
PTS 7,5 - 100	7,5	15,8	1440	1440	△	△-△			
PTSex 7,5 - 100									
PTS 9 - 100	9	19	1440	1440	△	△-△			
PTSex 9 - 100									
PTS 15 - 100K	15	30	975	975	△	△-△			
PTS 25 - 100K	25	47	1465	1465	△	△-△			
PTS 30 - 100K	30	56	1465	1465	△	△-△			
PTS 37 - 100K	37	68	1475	1475	△	△-△			
PTS 45 - 100K	45	82	1475	1475	△	△-△			
PTS 11 - 150	11	23,5	1450	1450	△	△-△			
PTSex 11 - 150									
PTS 15 - 150	15	30	1450	1450	△	△-△			
PTSex 15 - 150									
PTS 18,5 - 150	18,5	36	1465	1465	△	△-△			
PTSex 18,5 - 150									
PTS 15 - 200	15	30	975	975	△	△-△			
PTS 18,5 - 200	18,5	38	975	975	△	△-△			
PTS 22 - 200	22	43	980	980	△	△-△			
PTS 25 - 200	25	48	980	980	△	△-△			
PTS 30 - 200	30	58	980	980	△	△-△			

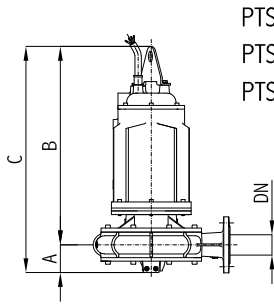

PTS ... - 65
PTS ... - 80
PTS ... - 100K

Flangia UNI
Flange UNI
Bride UNI

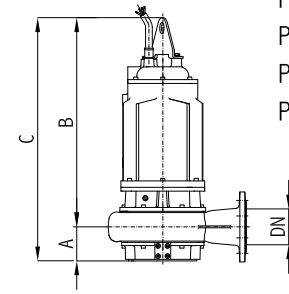
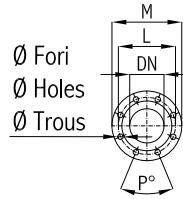

PTS ... - 80N
PTS ... - 100
PTS ... - 150
PTS ... - 200

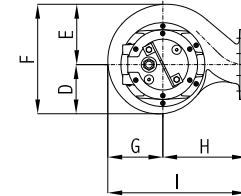
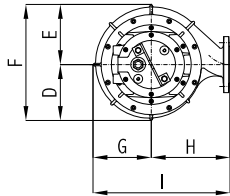

Flangia - Flange - Bride					
DN	L	M	P°	Ø Fori Ø Holes Ø Troux	N°Fori N°Holes N°Troux
DN65-PN10	145	185	90°	18	4
DN80-PN10	160	200	90°	18	4
DN100-PN10	180	220	45°	18	8
DN150-PN10	240	285	45°	22	8
DN200-PN10	295	340	45°	22	8

Elettropompa tipo Electric pump type Electropompe type		DIMENSIONI INGOMBRO - OVERALL DIMENSIONS - DIMENSIONS [mm]										Peso Weight Poids [kg]								
		DN	A	B	C	D	E	F	G	H	I									
PTS 7,5 - 65	PTSex 7,5 - 65	DN65 PN10	92	656	748	184	199	383	192	261	453	125								
PTS 9 - 65	PTSex 9 - 65			773	865							130								
PTS 11 - 65	PTSex 11 - 65											191								
PTS 2,2 - 80	PTSex 2,2 - 80	DN80 PN10	107	579	686	150	177	327	163	240	403	74								
PTS 3 - 80	PTSex 3 - 80													77						
PTS 4 - 80	PTSex 4 - 80													78						
PTS 15 - 80	PTSex 15 - 80			775	882							168,5								
PTS 18,5 - 80	PTSex 18,5 - 80											183								
PTS 2,2 - 80N	PTSex 2,2 - 80N											75								
PTS 3 - 80N	PTSex 3 - 80N			579	686							78								
PTS 4 - 80N	PTSex 4 - 80N											79								
PTS 15 - 80N	PTSex 15 - 80N			776	883							169,5								
PTS 18,5 - 80N	PTSex 18,5 - 80N											184								
PTS 4 - 100	PTSex 4 - 100			DN100 PN10	108							570	677	155	190	345	173	263	436	88
PTS 5,5 - 100	PTSex 5,5 - 100																			122
PTS 7,5 - 100	PTSex 7,5 - 100					128														
PTS 9 - 100	PTSex 9 - 100					133														
PTS 15 - 100K						445														
PTS 25 - 100K		1090	1207			463														
PTS 30 - 100K		117	1287			232	251	483	242	370	612	475								
PTS 37 - 100K								565												
PTS 45 - 100K								579												
PTS 11 - 150	PTSex 11 - 150	DN150 PN10	150			805	955	197	257	454	226	342	568							213
PTS 15 - 150	PTSex 15 - 150			226																
PTS 18,5 - 150	PTSex 18,5 - 150			229																
PTS 15 - 200		DN200 PN10	244	1051	1295	296	364	660	380	480	860	475								
PTS 18,5 - 200												490								
PTS 22 - 200				1131	1375							565								
PTS 25 - 200												577								
PTS 30 - 200												601								

INSTALLAZIONI POSSIBILI - POSSIBLE INSTALLATIONS - INSTALLATIONS POSSIBLES

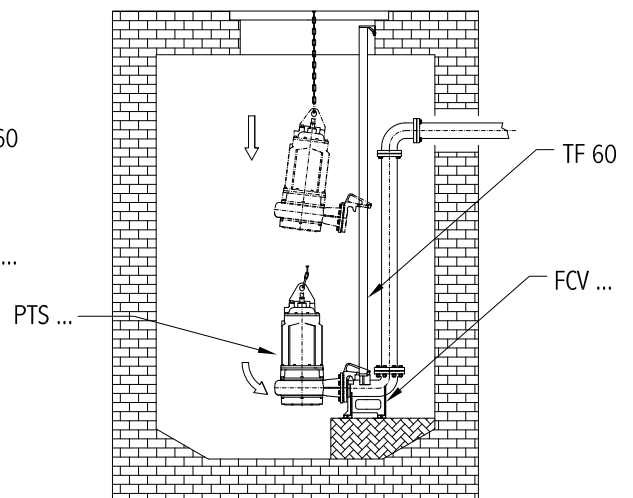
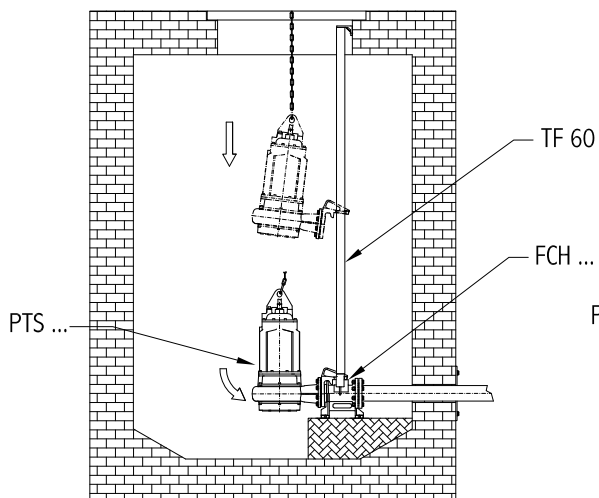
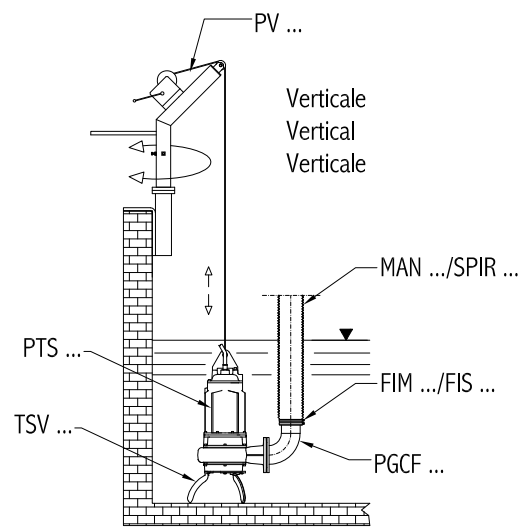
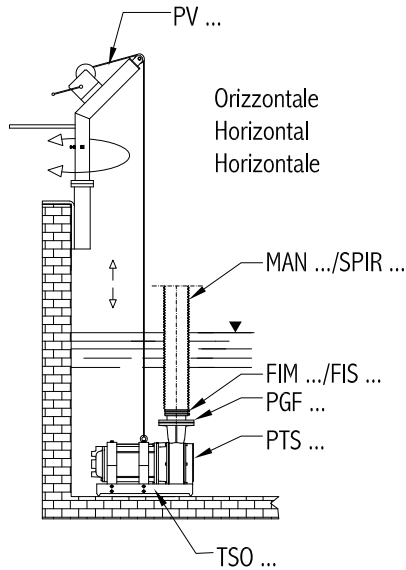
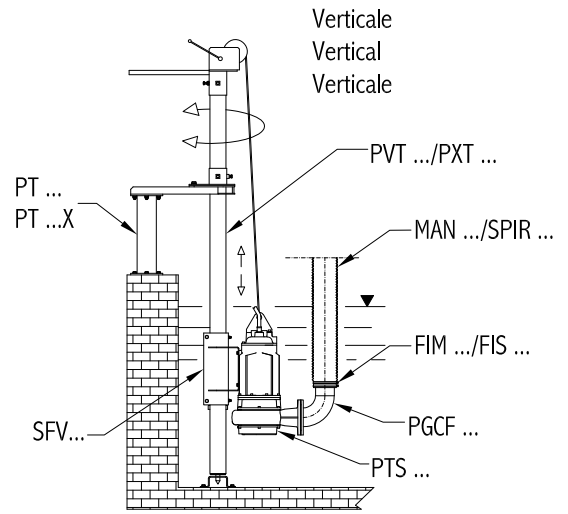
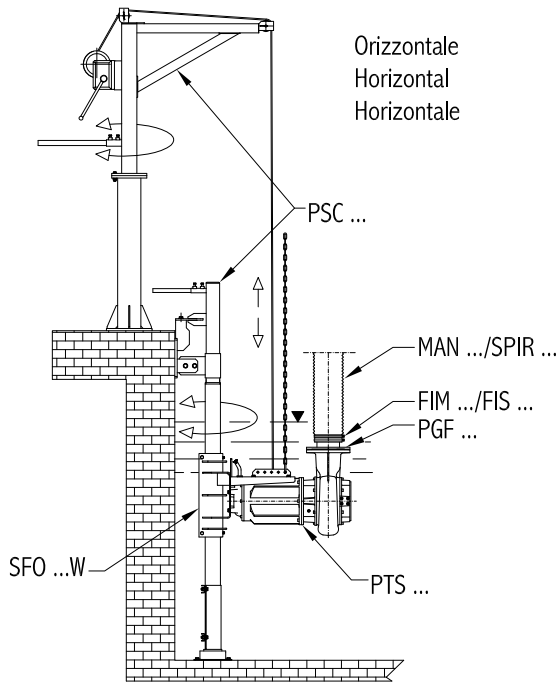

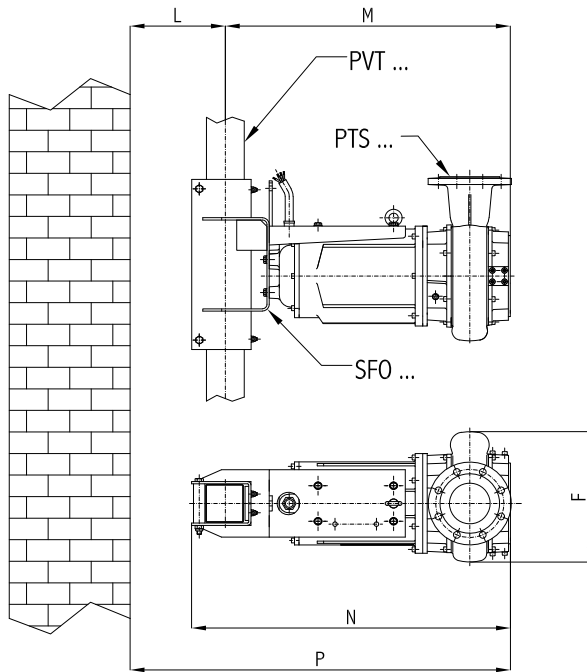

Elettropompa tipo Electric pump type Electropompe type	DIMENSIONI [mm] DIMENSIONS [mm] DIMENSIONS [mm]				
	F	L	M	N	P
PTS 7,5/9-65	383	240	735	825	1065
PTSex 7,5/9-65					
PTS 11-65		250	822	911	1545
PTSex 11-65					
PTS 2,2/3/4-80/80N	327	240	658	737	898
PTSex 2,2/3/4-80/80N					
PTS 15/18,5-80/80N		250	843	933	1093
PTSex 15/18,5-80/80N					
PTS 4-100	345	240	664	743	904
PTSex 4-100					
PTS 5,5/7,5/9-100		250	753	843	1003
PTSex 5,5/7,5/9-100					
PTS 15/25/30-100K	483	285	1172	1295	1457
PTS 37/45-100K				
PTS 11/15/18,5-150	454	250	910	1000	1160
PTSex 11/15/18,5-150					
PTS 15/18,5-200				
PTS 22/25/30-200				

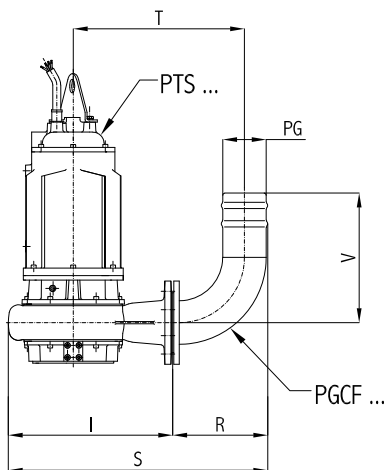





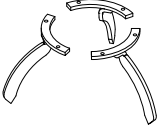

Elettropompa tipo Electric pump type Electropompe type	DIMENSIONI [mm] DIMENSIONS [mm] DIMENSIONS [mm]					
	PG	I	R	S	T	V
PTS 7,5/9/11-65	DN60	453	115	568	660	185
PTSex 7,5/9/11-65						
PTS 2,2/3/4-80/80N	DN80	402	180	582	419	240
PTSex 2,2/3/4-80/80N						
PTS 15/18,5-80/80N						
PTSex 15/18,5-80/80N						
PTS 4-100	DN100	436	220	656	483	290
PTSex 4-100						
PTS 5,5/7,5/9-100						
PTSex 5,5/7,5/9-100						
PTS 15/25/30-100K						
PTS 37/45-100K						
PTS 11/15/18,5-150	DN150	568	320	888	660	380
PTSex 11/15/18,5-150						
PTS 15/18,5-200	DN200	860	440	1300	770	555
PTS 22/25/30-200						

ACCESSORI - ACCESSORIES - ACCESSOIRES

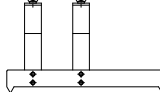
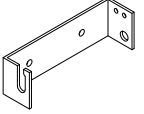
Elettropompa tipo Electric pump type Electropompe type	Paranco con verricello e tubo guida Hoist winch and rail pipe Treuil poulie et tuyau de guide		Kit di sollevamento Lifting kit Potence		Piantone Spacer Colonne			
PTS 7,5/9-65*	PVT 100 / 5	PXT 100 / 5	KIT PVT 100	KIT PXT 100	PT 100	PT 100X
PTS 11-65*	PVT 150 / 5N	PXT 150 / 5N	KIT PVT 150N, KIT PXT 150N	PT 100	PT 100X
PTS 2,2/3/4-80/80N*	PVT 80 / 5	PXT 80 / 5	PT 80	PT 80X
PTS 15/18,5-80/80N*	PVT 150 / 5N	PXT 150 / 5N	KIT PVT 150N, KIT PXT 150N	PT 100	PT 100X
PTS 4-100*	PVT 80 / 5	PXT 80 / 5	PT 80	PT 80X
PTS 5,5/7,5/9-100*	PVT 100 / 5	PXT 100 / 5	PT 100	PT 100X
PTS 15/25/30-100K	PVT 150R / 5	KIT PVT 150R / ...	PT 150R
PTS 37/45-100K
PTS 11/15/18,5-150*	PVT 150 / 5N	PXT 150 / 5N	KIT PVT 150N, KIT PXT 150N	PT 100	PT 100X
PTS 15/18,5-200
PTS 22/25/30-200
Elettropompa tipo Electric pump type Electropompe type	Fermacavo Cable stop Arrêt de câble	Staffa motore Motor bracket Support du moteur	Staffa motore Motor bracket Support du moteur	Gru con verricello Cranes and winch Grues et poulie		Staffa motore con rullini Motor bracket with rolls Support du mot. avec rouleaux		
PTS 7,5/9-65*	FC 20	SFV 100D	SFO 100	PSC 100 / 5		SFO 100W		
PTS 11-65*	FC 26	SFV 150	SFO 150	PSC 100 / 5		SFO 150W		
PTS 2,2/3/4-80/80N*	FC 16	SFV 80	SFO 80	PSC 80 / 5		SFO 80W		
PTS 15/18,5-80/80N*	FC 26	SFV 150	SFO 150	PSC 100 / 5		SFO 150W		
PTS 4-100*	FC 16	SFV 80	SFO 80	PSC 80 / 5		SFO 80W		
PTS 5,5/7,5/9-100*	FC 20	SFV 100	SFO 100	PSC 100 / 5		SFO 100W		
PTS 15-100K	FC 26	SFV 180	SFO 180	PSC 150R / 5		SFO 180W		
PTS 25/30-100K	FC 30				
PTS 37-100K		
PTS 45-100K	FC 28		
PTS 11/15/18,5-150*	FC 26	SFV 150	SFO 150	PSC 100 / 5		SFO 150W		
PTS 15/18,5-200	FC 26		
PTS 22/25/30-200	FC 30		
Elettropompa tipo Electric pump type Electropompe type	Staffa motore con rullini Motor bracket with rolls Support du mot. avec rouleaux	Kit gru con verricello Cranes and winch kit Kit grues et poulie	Kit fissaggio tubo guida Fixing kit for rail pipe Kit de fixation pour tuyau de guide	Tubo guida Guide tube Tuyaux guide	Paranco con verricello Hoist and winch Treuil et poulie			
PTS 7,5/9-65*	SFV 100WD	KIT PVG 100	KIT PTG 100	KIT PGI 100	PV 100	PV 100X		
PTS 11-65*	SFV 150W				PV 150	PV 150X		
PTS 2,2/3/4-80/80N*	SFV 80W	KIT PVG 80	KIT PTG 80	KIT PGI 80	PV 80	PV 80X		
PTS 15/18,5-80/80N*	SFV 150W	KIT PVG 100	KIT PTG 100	KIT PGI 100	PV 150	PV 150X		
PTS 4-100*	SFV 80W	KIT PVG 80	KIT PTG 80	KIT PGI 80	PV 80	PV 80X		
PTS 5,5/7,5/9-100*	SFV 100W	KIT PVG 100	KIT PTG 100	KIT PGI 100	PV 100	PV 100X		
PTS 15/25/30-100K	KIT PVG 150R	KIT PTG 150R	KIT PGI 150R	PV 150R		
PTS 37/45-100K		
PTS 11/15/18,5-150*	SFV 150W	KIT PVG 100	KIT PTG 100	KIT PGI 100	PV 150	PV 150X		
PTS 15/18,5-200		
PTS 22/25/30-200		
*PTS... = PTSex ...	PVT... / KIT PVT... / PSC... / KIT PVG... / PV... = Attrezzature con arganello zincato - Equipment with galvanized winch - Équipement de treuil galvanisé PXT... / KIT PXT... / PT...X / PV...X = Attrezzature in acciaio inox - Stainless steel equipment - Équipement en acier inoxydable							

ACCESSORI - ACCESSORIES - ACCESSOIRES

Elettropompa tipo Electric pump type Electropompe type	Telaio di sostegno Support frame Châssis de soutien		Telaio di sostegno Support frame Châssis de soutien	Piedi di sostegno Support feet Pieds de soutien	Staffa attacco catena e fune Bracket for chain and rope Support pour chaîne et corde
					
PTS 7,5/9-65*		TSV 65	TSO 100 TSO 100X
PTS 11-65*		TSV 65	TSO 150 TSO 150X
PTS 2,2/3/4-80/80N*	TSV 80 TSV 80X	TSO 80 TSO 80X
PTS 15/18,5-80/80N*				TSO 150 TSO 150X	
PTS 4-100*	TSV 100 TSV 100X	TSO 80 TSO 80X	SCF
PTS 5,5/7,5/9-100*				TSO 100 TSO 100X	
PTS 15/25/30-100K				
PTS 37/45-100K	TSV 100K	PSO 100K/180	PSO 100K/225
PTS 11/15/18,5-150*	TSV 150 TSV 150X	TSO 150 TSO 150X
PTS 15/18,5-200	TSV 200	PSO 200/180	PSO 200/225
PTS 22/25/30-200	TSV 200	PSO 200/180	PSO 200/225

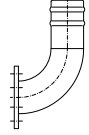
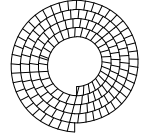
Elettropompa tipo Electric pump type Electropompe type	Catena Chain Chaîne	Grillo Shackle Cricket	Portagomma flangiato Flanged hose connection Raccord bridé	Curva flangiata portagomma Flanged hose connection Coude bridé de refoulement pour tuyau flexible	Manichetta / Tubo flessibile Flexible rubber hose / PVC hose Tuyau flexible / Tuyau en PVC
					
PTS 7,5/9-65*	CAT INOX 6	GRI 10	PGF 60/65 PGF 60/65 Z	PGCF 60/65 PGCF 60/65 Z	SPIR 60
PTS 11-65*		GRI 10	PGF 60/65 PGF 60/65 Z	PGCF 60/65 PGCF 60/65 Z	SPIR 60
PTS 2,2/3/4-80/80N*		GRI 8	PGF 80 PGF 80 Z	PGCF 80 PGCF 80 Z PGCF 100/80	SPIR 80
PTS 15/18,5-80/80N*		GRI 10	PGF 100/80	PGCF 80 PGCF 80 Z PGCF 100/80	SPIR 80
PTS 4-100*		GRI 8	PGF 100 PGF 120-100	PGCF 100 PGCF 120-100	MAN 100 SPIR 100 SPIR 120
PTS 5,5/7,5/9-100*	CAT INOX 8	GRI 10	PGF 100 Z PGF 120-100 Z	PGCF 100 Z PGCF 120-100 Z	MAN 100 SPIR 100 SPIR 120
PTS 15/25/30-100K	CAT INOX 12	GRI 14	PGF 100 Z PGF 120-100 Z	PGCF 100 Z PGCF 120-100 Z	MAN 100 SPIR 100 SPIR 120
PTS 37/45-100K	CAT INOX 12	GRI 14	PGF 100 Z PGF 120-100 Z	PGCF 100 Z PGCF 120-100 Z	MAN 100 SPIR 100 SPIR 120
PTS 11/15/18,5-150*	CAT INOX 6	GRI 10	PGF 150 PGF 150 Z	PGCF 150 PGCF 150 Z	MAN 150 SPIR 150
PTS 15/18,5-200	CAT INOX 12	GRI 14	PGF 200 PGF 200 Z	PGCF 200 PGCF 200 Z	MAN 200
PTS 22/25/30-200	CAT INOX 12	GRI 14	PGF 200 PGF 200 Z	PGCF 200 PGCF 200 Z	MAN 200

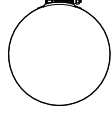
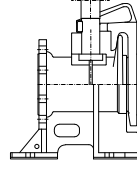
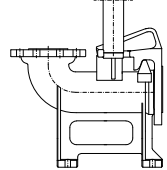
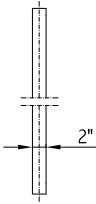
Elettropompa tipo Electric pump type Electropompe type	Fascetta per manichetta / ... per tubo flessibile Clamp for rubber hose / Clamp for PVC hose Collier de serrage pour tuyau flexible / ... pour tuyau en PVC	Piede Duck-Foot pedestal Pied d'assise	Piede Duck-Foot pedestal Pied d'assise	Tubo guida Guide pipe Tuyaux guide
				
PTS 7,5/9-65*	FIS 60
PTS 11-65*	FIS 60
PTS 2,2/3/4-80/80N*	FIS 80	FCH 80-80	FCV 80-80N	TF 60
PTS 15/18,5-80/80N*	FIS 80	FCH 80-80	FCV 80-80N	TF 60
PTS 4-100*	FIM 100 FIS 100 FIS 120	FCH 100-100	FCV 100-100N	TF 60
PTS 5,5/7,5/9-100*	FIM 100 FIS 100 FIS 120	FCH 100-100	FCV 100-100N	TF 60
PTS 15/25/30-100K	FIM 100 FIS 100 FIS 120	FCH 100-100	FCV 100-100N	TF 60
PTS 37/45-100K	FIM 100 FIS 100 FIS 120	FCH 100-100	FCV 100-100N	TF 60
PTS 11/15/18,5-150*	FIM 150 FIS 150	FCH 150-150	FCV 150-200	TF 60
PTS 15/18,5-200	FIM 200	FCV 200-200	TF 60
PTS 22/25/30-200	FIM 200	FCV 200-200	TF 60
*PTS... = PTSex ...				

FCV 80-80N
 FCV 100-100N
 FCV 150-200

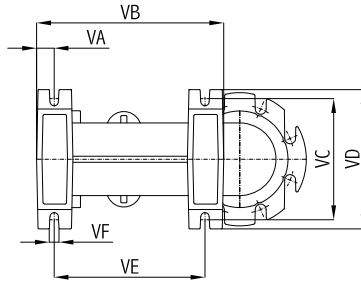

Flangia UNI
 Flange UNI
 Bride UNI

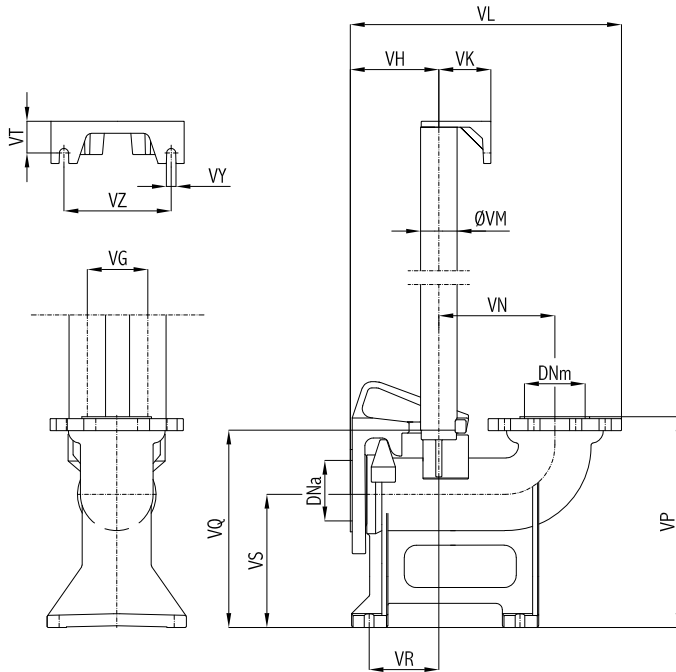
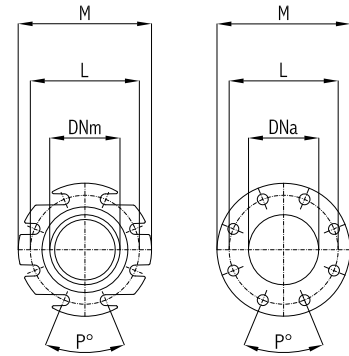

Flangia - Flange - Bride						
DNa	DNm	L	M	P°	Ø Fori Ø Holes Ø Trous	N°Fori N°Holes N°Trous
DN80-PN10		160	200	90°	M16	4
	DN80-PN10	160	200	90°	18	4
DN100-PN10		180	220	45°	M16	8
	DN100-PN10/16	180	220	45°	18	8
DN150-PN10		240	285	45°	M20	8
DN200-PN10		295	340	45°	M20	8
	DN200-PN10	295	340	45°	22	8
DN250-PN10		350	395	30°	22	12
	DN300-PN10	400	445	30°	22	12

Tipo
 Type
 Type

DIMENSIONI INGOMBRO
 OVERALL DIMENSIONS
 DIMENSIONS [mm]

	DNa	DNm	VA	VB	VC	VD	VE	VF	VG	VH	VK	VL	VM	VN	VP	VQ	VR	VS	VT	VY	VZ	H
FCV 80-80N	DN80-PN10	DN80-PN10	30	310	200	230	250	16	100	141	85	435	2"	194	353	336	115	229	55	16	174	300
FCV 100-100N	DN100-PN10	DN100-PN10/16																				
FCV 150-200	DN150-PN10	DN200-PN10	91	476	250	360	280	25	100	157	148	631	2"	304	603	606	63	408	50	14	100	500
FCV 200-200	DN200-PN10	DN200-PN10	62	623																		
FCV 250-300	DN250-PN10	DN300-PN10			310	425	24			88,5	117	673	3"	362	700	6	400		12,5	315		

Installazione
 Installation
 Installation

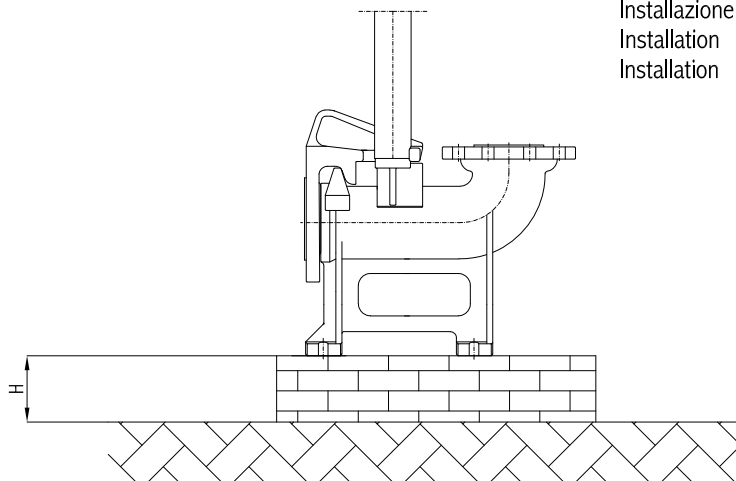

FCH 80-80
 FCH 100-100
 FCH 150-150

Flangia UNI
 Flange UNI
 Bride UNI

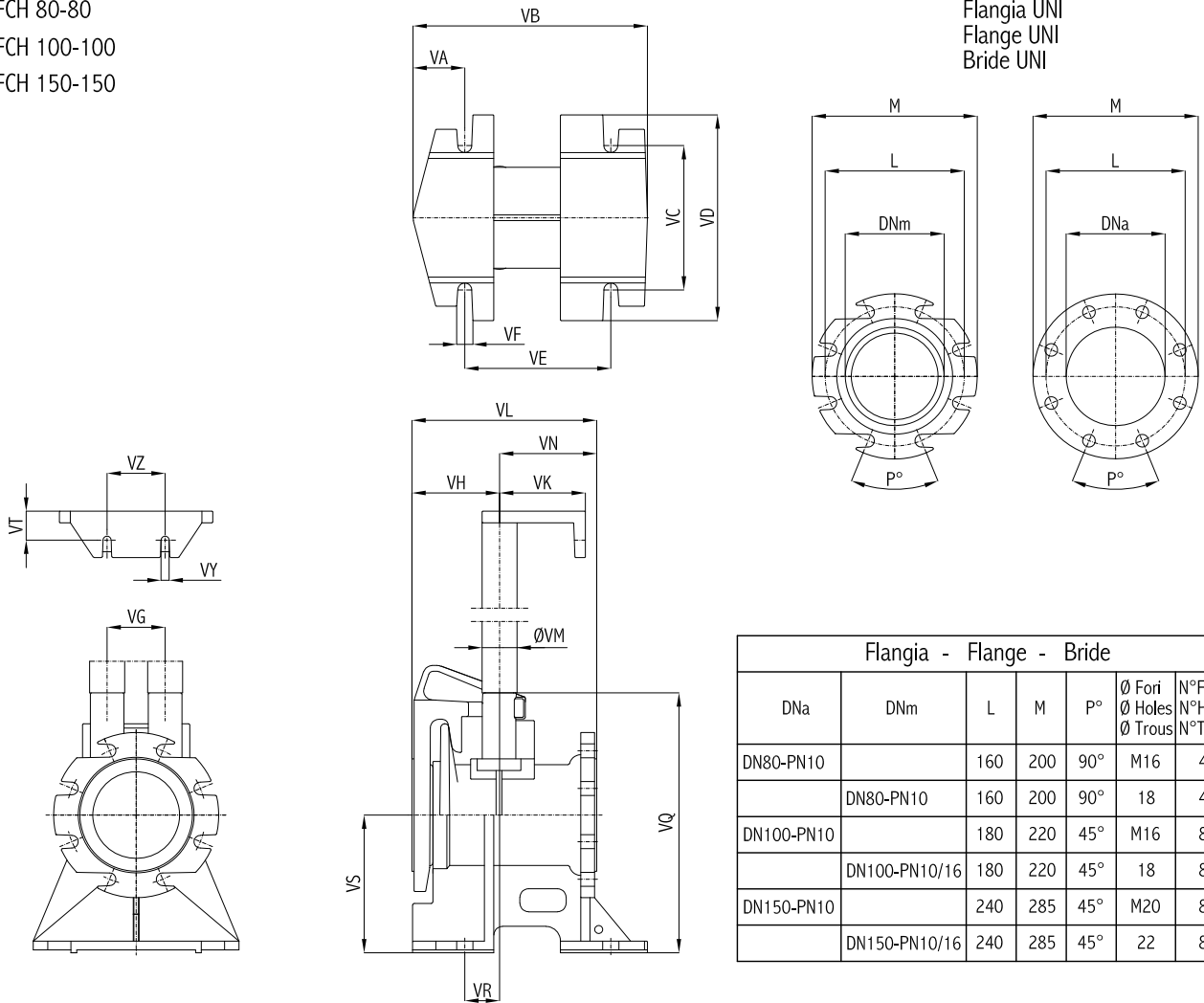

Tipo Type Type	DIMENSIONI INGOMBRO OVERALL DIMENSIONS DIMENSIONS [mm]																				
	DNa	DNm	VA	VB	VC	VD	VE	VF	VG	VH	VK	VL	VM	VN	VQ	VR	VS	VT	VY	VZ	
FCH 80-80	DN80-PN10	DN80-PN10	34	313	200	232		14		147	85	269		122	315	113		190	55		174
FCH 100-100	DN100-PN10	DN100-PN10/16	40	320			250	16	100			280	2"	133	331	105				15	
FCH 150-150	DN150-PN10	DN150-PN10/16	91	406	250	360		25		152	148	321		169	335	58		240	50		100

