



QUICK SELECTION / Selezione veloce

input speed (n_1) = 1400 min⁻¹

Output Speed n_2 [min ⁻¹]	Ratio i	Motor power P_{1M} [kW]	Output torque M_{2M} [Nm]	Service factor f.s.	Nominal power P_{1R} [kW]	Nominal torque M_{2R} [Nm]	Available B5 motor flanges		Available B14 motor flanges			Dynamic efficiency RD	Tooth Module [mm]	Ratios code
							-B	-C	-O	-P	-Q			
							63	71	56	63	71			
200	7	0.37	14	2.2	0.80	30	B		B-C	B-C		80	2.2	01
140	10	0.37	20	1.5	0.57	30	B		B-C	B-C		79	2.2	02
100	14	0.37	27	1.1	0.41	30	B		B-C	B-C		77	2.4	03
67	21	0.37	36	1.2	0.43	41	B		B-C	B-C		67	1.6	04
50	28	0.25	31	1.3	0.33	41	B		B-C	B-C		65	2.5	05
38	37	0.25	40	1.0	0.26	41	B		B-C	B-C		63	1.8	06
30	46	0.25	46	0.9	0.22	41	B		B-C	B-C		59	1.5	07
23	60	0.18	41	1.0	0.18	41	B		B-C	B-C		56	1.2	08
20	70	0.12	31	1.0	0.12	30	B		B-C	B-C		54	1.0	09
13.7	102	0.09	31	1.0	0.09	29	B		B-C	B-C		49	0.72	10

A Motor Flanges Available
Flange Motore Disponibili

B Supplied with Reduction Bushing
Fornito con Bussola di Riduzione

B Available on Request without reduction bushing
Disponibile a Richiesta senza Bussola di Riduzione

C Motor Flange Holes Position
Posizione Fori Flangia Motore

* Power higher than the maximum one which can be supported by the gearbox. Select according to the torque M_{2R}
Potenza superiore a quella massima sopportabile dal riduttore. Selezionare in base al momento torcente M_{2R}

EN Unit Q45 is supplied with synthetic oil, providing "long life" lubrication. For mounting position V5-V6 please contact us. See table 1 for lubrication and recommended quantity. In table 2 please see possible radial loads and axial loads on the gearbox.

I Il riduttore tipo Q45 viene fornito lubrificato a vita con olio sintetico. Per posizioni V5-V6 contattare il ns. servizio tecnico. Vedi tab.1 per oli e quantità consigliati. In tab.2 sono presenti i carichi radiali e assiali applicabili al riduttore.

D Für die Lebensdauerschmierung ist das Getriebe der Größe Q45 mit synthetischem Öl befüllt. Bei Einbaulage V5 oder V6 bitten wir um Rücksprache. In Tabelle 1 ist die Schmiermenge und das empfohlene Schmiermittel angegeben. In Tabelle 2 sind die zulässigen Radial- und Axialbelastungen des Getriebes aufgeführt.

F Le réducteur de type Q45 est fourni lubrifié à vie avec de l'huile synthétique. Concernant les positions V5.V6, contactez notre service d'assistance technique. Voir tableau 1 concernant les huiles et les quantités conseillées. Les charges radiales et axiales applicables au réducteur sont précisées dans le tableau 2.

E El reductor tamaño Q45 se suministra, lubricado de por vida con aceite sintético. Para las posiciones V5 y V6 contactar con nuestro servicio técnico. Ver tabla 1, para cantidades y aceites recomendados. En la tabla 2, se encuentran las cargas radiales y axiales admitidas por el reductor.

LUBRICATION Q45 Oil Quantity 0.09 Lt.

AGIP Telium VSF 320

SHELL Omala S4 WE 320

For all details on lubrication and plugs check our website **tab. 1**
Per maggiori dettagli su lubrificazione e tappi olio vedi il nostro sito web

RADIAL AND AXIAL LOADS

Output shaft
Albero di uscita

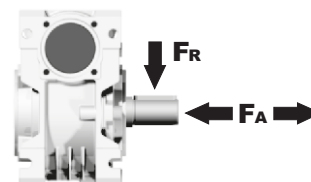

n_2 [min ⁻¹]	FA [N]	FR [N]
200	180	900
150	200	1000
100	220	1100
75	240	1200
50	260	1400
25	300	1800
15	400	2000

Input shaft
albero in entrata

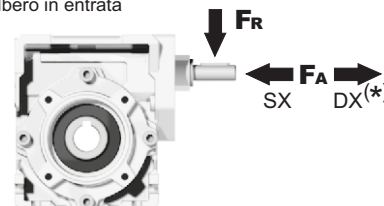

n_1 [min ⁻¹]	FA [N]	FR [N]
1400	42	210

*Strong axial loads in the DX direction are not allowed.
Non sono consentiti forti carichi assiali con direzione DX

tab. 2

PQ45FB... Basic wormbox
Riduttore base

M. flanges	Kit code	øF	A
63B5	K050.4.041	138	80
71B5	K050.4.042	160	77.5
56B14	KC40.4.049	80	77.5
63B14	K050.4.047	90	80
71B14	K050.4.045	105	77.5

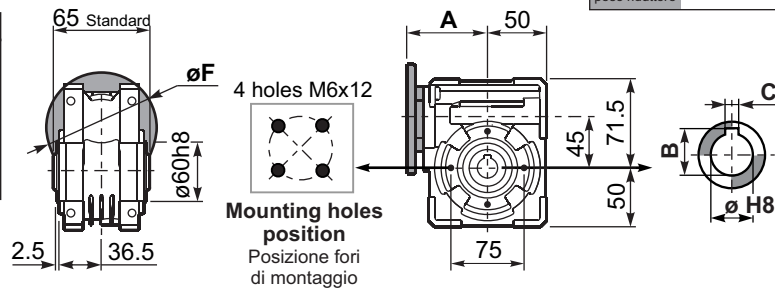

Gearbox weight
peso riduttore **2.30 kg**

ø H8	B	C	*Spacer code
18 Standard	20.8	6	Q45.3.018
19 on request	21.8	6	Q45.3.019
20 on request	22.8	6	Q45.3.020

*On Request
output shaft with spacers

PQ45FC... Square flange
Flangia quadrata

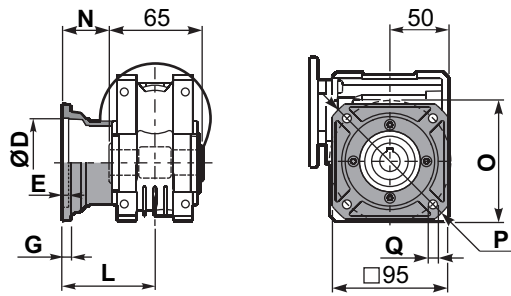

type B	øD	E	G	L	N	O	P	Q	kit code
FC	60 H8	4	7	67	34.5	75	110	9	KQ45.9.010
FL	60 H8	4	7	97	64.5	75	110	9	KQ45.9.011

PQ45F1... Round flange
Flangia rotonda

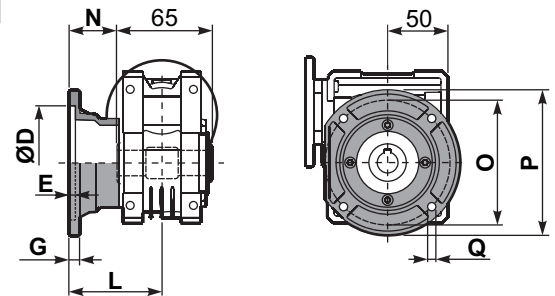

type S	øD	E	G	L	N	O	P	Q	kit code
F1	95H8	5	9	80	47.5	115	140	9.5	KSQ45.9.012
F2	-	-	-	-	-	-	-	-	-

PQ45FB... Feet
Piedini

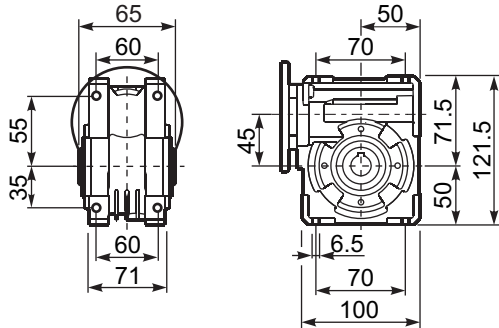

PQ45BR... Reaction arm
Braccio di reazione

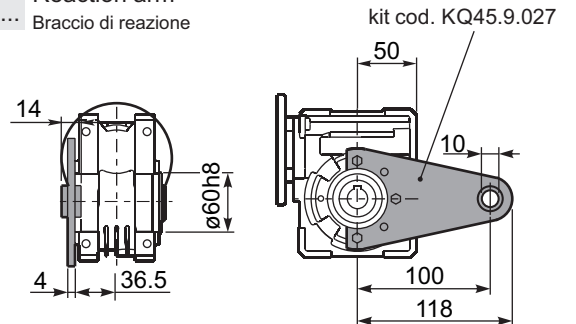

RQ45FB... Input shaft
Albero in entrata

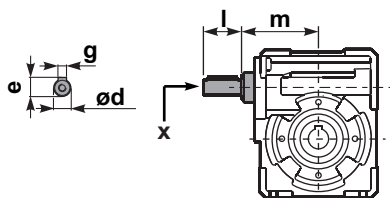

	ød	e	g	l	m	x	kit code
type B	11 h6	12.5	4	30	74	-	① K045.5.006 PAM71 ② -
type S	-	-	-	-	-	-	① - ② -

PQ45.....S... Single Shaft
Albero lento semplice

PQ45.....D... Double Shaft
Albero lento bisp.

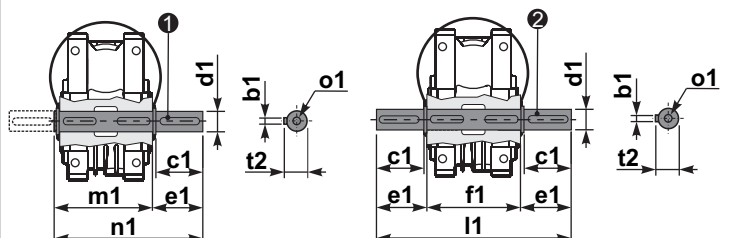

① kit cod. K045.5.028 type B
kit cod. KS045.5.030 type S
② kit cod. K045.5.029 type B

	b1	c1	d1	e1	f1	l1	m1	n1	t2	o1
type B	6	32	18 ^{-0.005} _{-0.020}	43	65	151	70	113	20.5	M6x18
type S	6	40	19 ^{-0.005} _{-0.020}	58.5	-	-	70	128.5	21.5	M8x20