



QUICK SELECTION / Selezione veloce

input speed (n_1) = 1400 min⁻¹

Output Speed n_2 [min ⁻¹]	Ratio i	Motor power P_{1M} [kW]	Output torque M_{2M} [Nm]	Service factor f.s.	Nominal power P_{1R} [kW]	Nominal torque M_{2R} [Nm]	Available B5 motor flanges			Available B14 motor flanges				Dynamic efficiency RD	Tooth Module [mm]	Ratios code
							-B	-C	-D	-O	-P	-Q	-R			
							63	71	80	56	63	71	80			
200	7	0.75	29	1.9	1.5	57	B	B			B-C	B		82	2.5	01
140	10	0.75	41	1.5	1.1	62	B	B			B-C	B		80	2.4	02
100	14	0.75	57	1.2	0.90	68	B	B			B-C	B		79	2.6	03
78	18	0.55	51	1.2	0.67	62	B	B			B-C	B		75	2.0	04
54	26	0.55	67	1.0	0.54	66	B	B			B-C	B		69	2.7	05
47	30	0.55	79	0.9	0.50	72	B	B			B-C	B		70	2.5	12
39	36	0.37	63	1.2	0.43	72	B			B-C	B-C		69	2.1	06	
33	43	0.37	72	1.0	0.35	68	B			B-C	B-C		66	1.8	07	
28	50	0.25	53	1.2	0.31	66	B			B-C	B-C		62	1.5	13	
23	60	0.25	59	1.0	0.26	62	B			B-C	B-C		58	1.3	08	
21	68	0.25	66	0.9	0.22	58	B			B-C	B-C		57	1.2	09	
17.5	80	0.18	53	1.1	0.19	57	B			B-C	B-C		54	1.0	10	
14	100	0.12	41	1.3	0.15	51	B			B-C	B-C		50	0.8	11	

A Motor Flanges Available
Flange Motore Disponibili

B Supplied with Reduction Bushing
Fornito con Bussola di Riduzione

B Available on Request without reduction bushing
Disponibile a Richiesta senza Bussola di Riduzione

C Motor Flange Holes Position
Posizione Fori Flangia Motore

EN Unit Q50 is supplied with synthetic oil, providing "long life" lubrication. For mounting position V5-V6 please contact us. See table 1 for lubrication and recommended quantity. In table 2 please see possible radial loads and axial loads on the gearbox.

I Il riduttore tipo Q50 viene fornito lubrificato a vita con olio sintetico. Per posizioni V5-V6 contattare il ns. servizio tecnico. Vedi tab.1 per oli e quantità consigliati. In tab.2 sono presenti i carichi radiali e assiali applicabili al riduttore.

D Für die Lebensdauerschmierung ist das Getriebe der Größe Q50 mit synthetischem Öl befüllt. Bei Einbaulage V5 oder V6 bitten wir um Rücksprache. In Tabelle 1 ist die Schmiermenge und das empfohlene Schmiermittel angegeben. In Tabelle 2 sind die zulässigen Radial - und Axialbelastungen des Getriebes aufgeführt.

F Le réducteur de type Q50 est fourni lubrifié à vie avec de l'huile synthétique. Concernant les positions V5.V6, contactez notre service d'assistance technique. Voir tableau 1 concernant les huiles et les quantités conseillées. Les charges radiales et axiales applicables au réducteur sont précisées dans le tableau 2.

E El reductor tamaño Q50 se suministra, lubricado de por vida con aceite sintético. Para las posiciones V5 y V6 contactar con nuestro servicio técnico. Ver tabla 1, para cantidades y aceites recomendados. En la tabla 2, se encuentran las cargas radiales y axiales admitidas por el reductor.

LUBRICATION Q50 Oil Quantity 0.14 Lt.

AGIP Telium VSF 320

SHELL Omala S4 WE 320

For all details on lubrication and plugs check our website **tab. 1**
Per maggiori dettagli su lubrificazione e tappi olio vedi il nostro sito web

RADIAL AND AXIAL LOADS

Output shaft

Albero di uscita

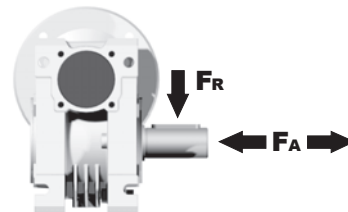

n_2 [min ⁻¹]	FA [N]	FR [N]
200	240	1200
150	280	1400
100	300	1500
75	340	1700
50	380	1900
25	480	2500
15	560	2800

Input shaft

albero in entrata

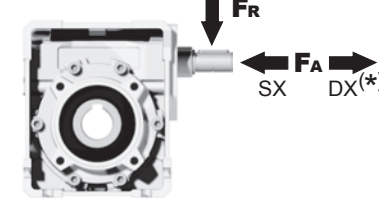

n_1 [min ⁻¹]	FA [N]	FR [N]
1400	76	380

*Strong axial loads in the DX direction are not allowed.
Non sono consentiti forti carichi assiali con direzione DX

tab. 2

PQ50**FB**... Basic wormbox
Riduttore base

Gearbox weight
peso riduttore **3.25 kg**

ø H8	B	C	*Spacer code
25 Standard	28.3	8	Q50.3.025
24 on request	27.3	8	Q50.3.024

M. flanges	Kit code	øF	A
63B5	K050.4.041	138	83.5
71B5	K050.4.042	160	81
80B5	K050.4.043	200	81.5
56B14	KC40.4.049	80	81
63B14	K050.4.047	90	83.5
71B14	K050.4.045	105	81
80B14	K050.4.046	120	81.5

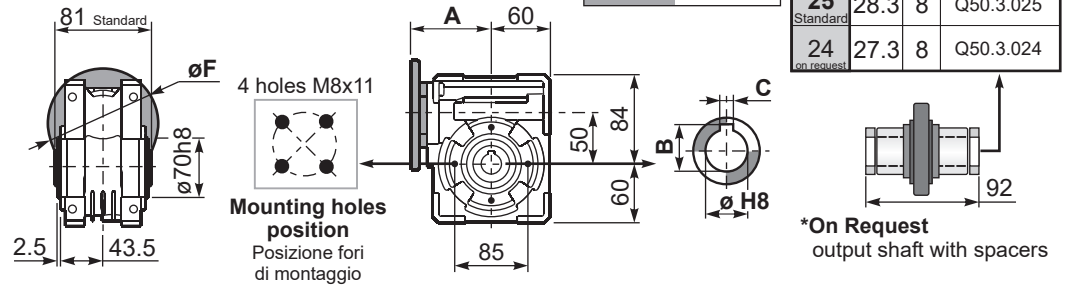

*On Request
output shaft with spacers

PQ50**FC**... Square flange
Flangia quadrata

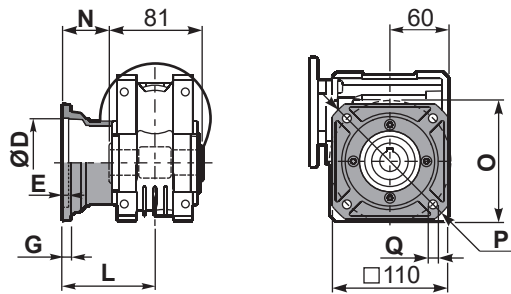

type B	øD	E	G	L	N	O	P	Q	kit code
FC	70 H8	5	9	90	49.5	85	125	11	KQ50.9.010
FL	70 H8	5	9	120	79.5	85	125	11	KQ50.9.011

PQ50**F1**... Round flange
Flangia rotonda

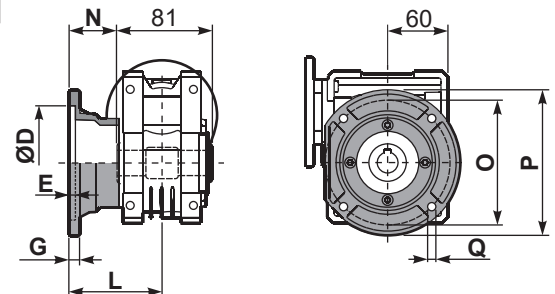

type S	øD	E	G	L	N	O	P	Q	kit code
F1	110 H8	5	10	89	48.5	130	160	9.5	KSQ50.9.012
F2	95 H8	5	14.5	72	31.5	115	140	11	KSQ50.9.013

PQ50**FB**... Feet
Piedini

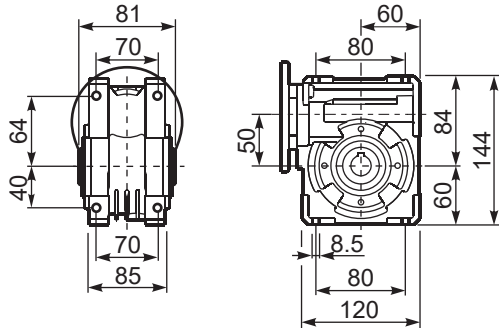

PQ50**BR**... Reaction arm
Braccio di reazione

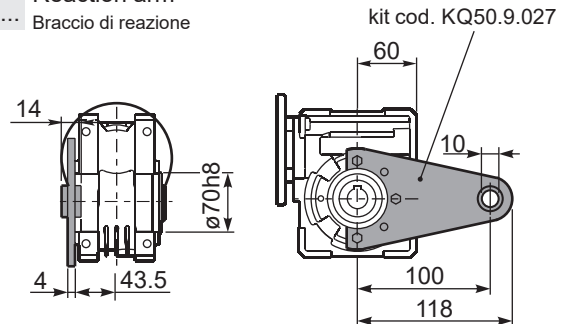

RQ50**FB**... Input shaft
Albero in entrata

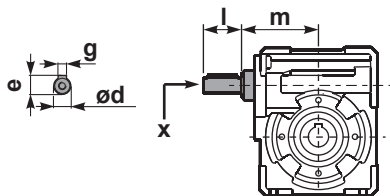

	ød	e	g	l	m	x	kit code
type B	16 h6	18	5	30	79.5	M6x16	① K050.5.006 PAM71 ② K050.5.007 PAM80
type S	14 h6	16	5	30	79.5	M5x10	① KS050.5.008 PAM71 ② KS050.5.009 PAM80

PQ50.....**S**... Single Shaft
Albero lento semplice

PQ50.....**D**... Double Shaft
Albero lento bisp.

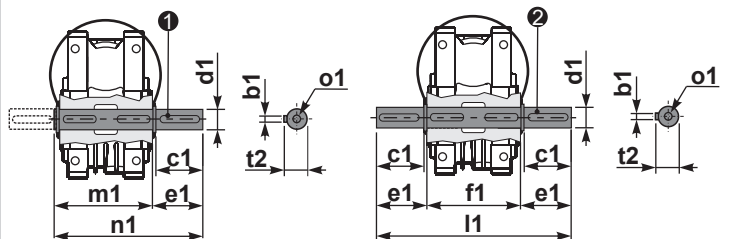

① kit cod. K050.5.028 type B
kit cod. KS050.5.030 type S
② kit cod. K050.5.029 type B

	b1	c1	d1	e1	f1	l1	m1	n1	t2	o1
type B	8	52	25 ^{-0.005} _{-0.020}	59.5	81	200	86.5	146	28	M8x20
type S	8	50	24 ^{-0.005} _{-0.020}	68.8	-	-	86.5	155	27	M8x20