

Enclosed Starters

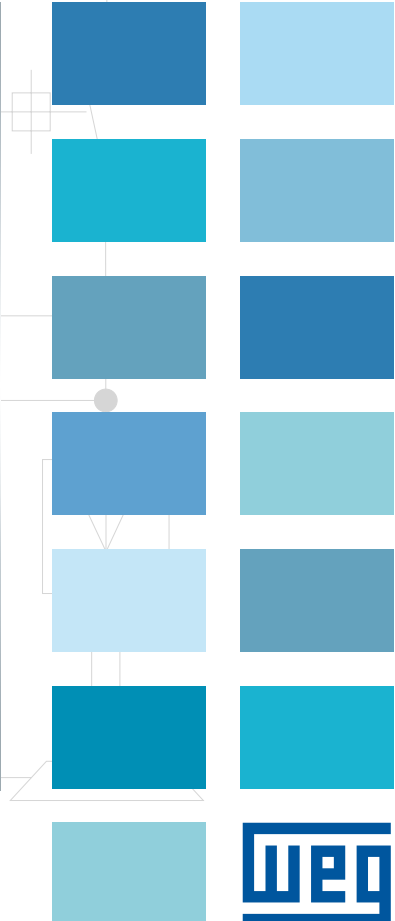

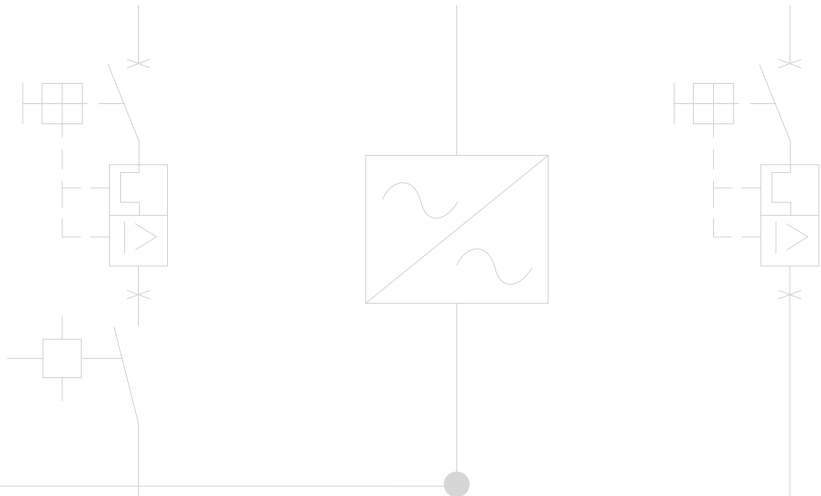

Enclosed Starters

Summary

Enclosed Starters	4
DLW - Enclosed Direct-On-Line Starters for Three-Phase Electric Motors	7
DLWM - Enclosed Direct-On-Line Starters for Single-Phase Electric Motors	9
Accessories	10
Wiring Diagram	11
Dimensions (mm)	13
Technical Data	13



Enclosed Starters

Enclosed starters developed for switching and protecting three-phase and single-phase electric motors. Four thermoplastic sizes comprising most possible applications.

Versions



Start + Stop/Reset operation (Standard)



Remote control (without buttons)



Stop/Reset operation (without Start button)



Hand/OFF/Auto + Start + Stop/Reset operation (Hand = Local control, OFF, Auto = Remote control)

Main Characteristics



Thermal overload relay reset button integrated to the Stop button (sizes 02 up to 05)

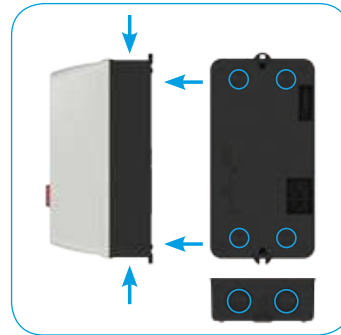

Allows cable connection in many different places

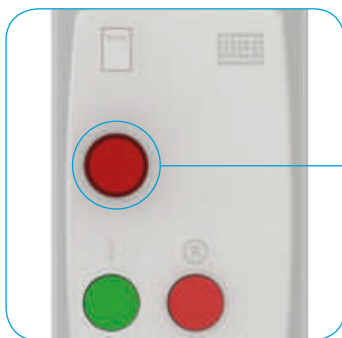

Compatible with CSW pushbuttons, switches and pilot lights (size 05 and 08)



Fast and easy installation of cable glands



Degree of protection IP65 to sizes: 02, 04 and 08 and IP66 (insulated of energized parts) to size: 05. Protected against dust and water jetting. Excellent insulating properties.



Enclosed size 05 allows installation of WEG electronic timers (RTW) or monitoring relays (RPW).



UV protection for outdoor use.



Robust and high impact resistance.

Main Certifications



Applications

Water Pumps and Irrigations Systems



Industries



Industrial and Residential Buildings



Machines and Equipments



Fans and Exhausters



Swimming Pools



DLW - Enclosed Direct-On-Line Starter

Three-phase starters

- Composition: contactor and thermal overload relay
- Degree of protection: IP65 or IP66⁴⁾
- Operational voltage up to 690 V and wide control voltage available
- Enclosure with UV protection and high mechanical shock resistance
- Short circuit protection has to be ensured by a separate short circuit protection facility



Orientative motor rated power 50/60 Hz ¹⁾					Setting range of overload relay  I _r (A)	Max. rated operational (A)	Reference to complete with control voltage code	Contactor	Thermal overload relay	Weight (kg)
230 V 240 V kW/hp	380 V kW/hp	400 V 415 V kW/hp	440 V kW/hp	690 V kW/hp						

Size 02

-	-	0.12/0.16	-	-	0.28...0.4	0.4	DLW-7■P65-R01	CW07	RW17-1D3-D004	0.53
-	0.12/0.16	0.18/0.25	-	-	0.4...0.63	0.63	DLW-7■P65-R02	CW07	RW17-1D3-C063	
0.12/0.16	0.18/0.25	0.25/0.33	-	-	0.56...0.8	0.8	DLW-7■P65-R03	CW07	RW17-1D3-D008	
0.18/0.25	0.25/0.33 0.37/0.5	0.37/0.5	-	-	0.8...1.2	1.2	DLW-7■P65-R04	CW07	RW17-1D3-D012	
0.25/0.33	0.55/0.75 0.75/1.0	0.55/0.75 0.75/1.0	-	-	1.2...1.8	1.8	DLW-7■P65-R05	CW07	RW17-1D3-D018	
0.37/0.5 0.55/0.75	0.75/1.0 1.1/1.5	1.1/1.5	-	-	1.8...2.8	2.8	DLW-7■P65-R06	CW07	RW17-1D3-D028	
0.75/1.0	1.5/2.0	1.5/2.0	-	-	2.8...4	4	DLW-7■P65-R07	CW07	RW17-1D3-U004	
1.1/1.5	2.2/3.0	2.2/3.0	-	-	4.0...6.3	6.3	DLW-7■P65-R08	CW07	RW17-1D3-D063	
1.5/2.0	3.0/4.0	3.0/4.0	-	-	5.6...8	7	DLW-7■P65-R09	CW07	RW17-1D3-U008	

Size 04

-	-	0.12/0.16	0.12/0.16	0.18/0.25	0.28...0.4	0.4	DLW-07■P65-R01	CWC07	RW17-1D3-D004	0.675
-	0.12/0.16	0.18/0.25	0.18/0.25	0.25/0.33	0.4...0.63	0.63	DLW-07■P65-R02	CWC07	RW17-1D3-C063	
0.12/0.16	0.18/0.25	0.25/0.33	0.25/0.33	0.37/0.5	0.56...0.8	0.8	DLW-07■P65-R03	CWC07	RW17-1D3-D008	
0.18/0.25	0.25/0.33 0.37/0.5	0.37/0.5	0.37/0.5	0.55/0.75 0.75/1	0.8...1.2	1.2	DLW-07■P65-R04	CWC07	RW17-1D3-D012	
0.25/0.33	0.55/0.75 0.75/1.0	0.55/0.75 0.75/1.0	0.55/0.75 0.75/1.0	1.1/1.5	1.2...1.8	1.8	DLW-07■P65-R05	CWC07	RW17-1D3-D018	
0.37/0.5 0.55/0.75	0.75/1.0 1.1/1.5	1.1/1.5	1.1/1.5	1.5/2 2.2/3	1.8...2.8	2.8	DLW-07■P65-R06	CWC07	RW17-1D3-D028	
0.75/1.0	1.5/2.0	1.5/2.0	1.5/2.0 2.2/3.0	3/4	2.8...4	4	DLW-07■P65-R07	CWC07	RW17-1D3-U004	
1.1/1.5	2.2/3.0	2.2/3.0	3.0/4.0	-	4.0...6.3	6.3	DLW-07■P65-R08	CWC07	RW17-1D3-D063	
1.5/2.0	3.0/4.0	3.0/4.0	4/5.5	-	5.6...8	7	DLW-07■P65-R09	CWC07	RW17-1D3-U008	
2.2/3.0	4/5.5	4/5.5	-	4.5/6	7...10	9	DLW-09■P65-R10	CWC09	RW17-1D3-U010	
3.0/4.0	5.5/7.5	5.5/7.5	5.5/7.5	5.5/7.5	8...12.5	12	DLW-012■P65-R11	CWC012	RW17-1D3-D125	
4/5.5	-	7.5/10	7.5/10	7.5/10	10...15	15	DLW-016■P65-R12	CWC016	RW17-1D3-U015	
-	7.5/10	-	9.2/12.5	-	11...17	16	DLW-016■P65-R13	CWC016	RW17-1D3-U017	

Control voltage (add suffix code)

Degree of protection: 65 (IP65)

Versions (add suffix code)

50/60 Hz ²⁾	220 V	230 V	240 V	400 V	415 V	500 V
■ Codes	D23	D24	D25	D34	D35	D40

Type of operation	Code
Start - Stop/Reset operation (standard)	P
Remote control (without buttons)	I
Stop/Reset operation (without ON button)	D
Hand/OFF/Auto operation (Hand = local control / Auto = remote control) + Start + Stop/Reset	B

Notes: 1) Some motors characteristics may vary according to each manufacturer;
 2) Other voltages available;
 3) For enclosed starters with others configurations only under request, consult your WEG local distributor;
 4) IP66 only for size 05.

DLW - Enclosed Direct-On-Line Starter

Three-phase starters

- Composition: contactor and thermal overload relay
- Degree of protection: IP65 or IP66³⁾
- Operational voltage up to 690 V and wide control voltage available
- Enclosure with UV protection and high mechanical shock resistance
- Short circuit protection has to be ensured by a separate short circuit protection facility



Orientative motor rated power 50/60 Hz ¹⁾					Setting range of overload relay  Ir (A)	Max. rated operational (A)	Reference to complete with control voltage code	Contactor	Thermal overload relay	Weight (kg)
230 V 240 V kW/hp	380 V kW/hp	400V 415V kW/hp	440 V kW/hp	690 V kW/hp						

Size 05					Setting range of overload relay  Ir (A)	Max. rated operational (A)	Reference to complete with control voltage code	Contactor	Thermal overload relay	Weight (kg)
230 V 240 V kW/hp	380 V kW/hp	400V 415V kW/hp	440 V kW/hp	690 V kW/hp						
-	-	-	0.12	0.18/0.26	0.28...0.4	0.4	DLW-B9■P66-R54	CWB9	RW27-2D3-D004	0.985
-	0.12/0.16	0.18/0.25	0.18/0.25	0.25/0.33	0.4...0.63	0.63	DLW-B9■P66-R55	CWB9	RW27-2D3-C063	
0.12/0.16	0.18/0.25	0.25/0.33	0.25/0.33	0.37/0.5	0.56...0.8	0.8	DLW-B9■P66-R56	CWB9	RW27-2D3-D008	
0.18/0.25	0.25/0.33 0.37/0.5	0.37/0.5	0.37/0.5	0.55/0.75 0.75/1	0.8...1.2	1.2	DLW-B9■P66-R57	CWB9	RW27-2D3-D012	
0.25/0.33	0.55/0.75	0.55/0.75 0.75/1	0.55/0.75 0.75/1	1.1/1.5	1.2...1.8	1.8	DLW-B9■P66-R58	CWB9	RW27-2D3-D018	
0.37/0.5 0.55/0.75	0.75/1 1.1/1.5	1.1/1.5	1.1/1.5	1.5/2 2.2/3	1.8...2.8	2.8	DLW-B9■P66-R59	CWB9	RW27-2D3-D028	
0.75/1	1.5/2	1.5/2.0	1.5/2 2.2/3	3/4	2.8...4.0	4.0	DLW-B9■P66-R60	CWB9	RW27-2D3-U004	
1.1/1.5	2.2/3	2.2/3.0	3/4	3.7/5	4.0...6.3	6.3	DLW-B9■P66-R61	CWB9	RW27-2D3-D063	
1.5/2	3/4	3/4	4/5.5	5.5/7.5	5.6...8.0	8.0	DLW-B9■P66-R62	CWB9	RW27-2D3-U008	
2.2/3	4/5.5	4/5.5	-	-	7.0...10	9.0	DLW-B9■P66-R63	CWB9	RW27-2D3-U010	
3/4	5.5/7.5	5.5/7.5	5.5/7.5	7.5/10	8.0...12.5	12	DLW-B12■P66-R64	CWB12	RW27-2D3-D125	
4/5.5	-	7.5/10	7.5/10	9.2/12.5 11/15	10...15	15	DLW-B18■P66-R65	CWB18	RW27-2D3-U015	
-	7.5/10	-	9.2/12.5	-	11...17	17	DLW-B18■P66-R66	CWB18	RW27-2D3-U017	
-	-	-	-	-	15...23	18	DLW-B18■P66-R67	CWB18	RW27-2D3-U023	
5.5/7.5	9.2/12.5 11/15	11/15	11/15	-	15...23	23	DLW-B25■P66-R67	CWB25	RW27-2D3-U023	
-	-	-	-	-	22...32	25	DLW-B25■P66-R68	CWB25	RW27-2D3-U032	
7.5/10	15/20	15/20	15/20	-	22...32	32	DLW-B32■P66-R68	CWB32	RW27-2D3-U032	
-	-	-	-	-	25...40	32	DLW-B32■P66-R69	CWB32	RW27-2D3-U040	
9.2/12.5 11/15	18.5/25	18.5/25	18.5/25 22/30	-	25...40	38	DLW-B38■P66-R69	CWB38	RW27-2D3-U040	

Size 08					Setting range of overload relay  Ir (A)	Max. rated operational (A)	Reference to complete with control voltage code	Contactor	Thermal overload relay	Weight (kg)
230 V 240 V kW/hp	380 V kW/hp	400V 415V kW/hp	440 V kW/hp	690 V kW/hp						
9.2/12.5 11/15	18.5/25	18.5/25	18.5/25 22/30	30/40	25...40	40	DLW-50■P65-R36	CWM50	RW67-2D3-U040	3.100
-	22/30	22/30	-	-	40...57	50	DLW-50■P65-R39	CWM50	RW67-2D3-U057	
15/20	-	30/40	30/40	37/50	40...57	57	DLW-65■P65-R39	CWM65	RW67-2D3-U057	
18.5/25	30/40	-	37/50	-	50...63	63	DLW-65■P65-R40	CWM65	RW67-2D3-U063	
-	-	37/50	-	-	57...70	70	DLW-80■P65-R41	CWM80	RW67-2D3-U070	
22/30	37/50	-	45/60	-	63...80	80	DLW-80■P65-R42	CWM80	RW67-2D3-U080	

Control voltage (add suffix code)



Degree of protection: 65 (IP65) or 66 (IP66)³⁾

Versions (add suffix code)

50/60 Hz ²⁾	220 V	230 V	240 V	400 V	415 V	500 V
■ Codes	D23	D24	D25	D34	D35	D40

Type of operation	Code
Start - Stop/Reset operation (standard)	P
Remote control (without buttons)	I
Stop/Reset operation (without ON button)	D
Hand/OFF/Auto operation (Hand = local control / Auto = remote control) + Start + Stop/Reset	B

Notes: 1) Some motors characteristics may vary according to each manufacturer;
 2) Other voltages available;
 3) IP66 only for size 05;
 4) For enclosed starters with others configurations only under request, consult your WEG local distributor.

DLWM - Enclosed Direct-On-Line Starter

Single-phase starters

- Composition: contactor and thermal overload relay
- Degree of protection: IP65 or IP66³⁾
- Wide control voltage available
- Enclosure with UV protection and high mechanical shock resistance
- Short circuit protection has to be ensured by a separate short circuit protection facility



Orientative motor rated power 50/60 Hz ¹⁾		Setting range of overload relay	Max. rated operational	Reference to complete with control voltage code	Contactor	Thermal overload relay	Weight
230 V kW/hp		 Ir (A)	(A)				(kg)

Size 02

0.18/0.25	1.2...1.8	1.8	DLWM-7■P65-RM05	CW07	RW17-1D2-D018	0.530
0.25/0.33	1.8...2.8	2.8	DLWM-7■P65-RM06	CW07	RW17-1D2-D028	
0.37/0.5	2.8...4	4	DLWM-7■P65-RM07	CW07	RW17-1D2-U004	
0.75/1	4...6.3	6.3	DLWM-7■P65-RM08	CW07	RW17-1D2-D063	
1.1/1.5	5.6...8	7	DLWM-7■P65-RM09	CW07	RW17-1D2-U008	

Orientative motor rated power 50/60 Hz ¹⁾		Setting range of overload relay	Max. rated operational	Reference to complete with control voltage code	Contactor	Thermal overload relay	Weight
230 V kW/hp	460 V kW/hp	 Ir (A)	(A)				(kg)

Size 05

-	0.25/0.33	0.8...1.2	1.2	DLWM-B9■P66-RM57	CWB9	RW27-2D2-D012	0.804
0.18/0.25	0.37/0.5	1.2...1.8	1.8	DLWM-B9■P66-RM58	CWB9	RW27-2D2-D018	
0.25/0.33	0.75/1	1.8...2.8	2.8	DLWM-B9■P66-RM59	CWB9	RW27-2D2-D028	
0.37/0.5	1.1/1.5	2.8...4	4	DLWM-B9■P66-RM60	CWB9	RW27-2D2-U004	
0.55/0.75	1.5/2	4...6.3	6.3	DLWM-B9■P66-RM61	CWB9	RW27-2D2-D063	
1.1/1.5	2.2/3	5.6...8	8	DLWM-B9■P66-RM62	CWB9	RW27-2D2-U008	0.815
-	3/4	7...10	9	DLWM-B9■P66-RM63	CWB9	RW27-2D2-U010	
1.5/2	3.7/5	8...12.5	12	DLWM-B12■P66-RM64	CWB12	RW27-2D2-D125	
2.2/3	-	10...15	15	DLWM-B18■P66-RM65	CWB18	RW27-2D2-U015	0.860
-	5.5/7.5	11...17	17	DLWM-B18■P66-RM66	CWB18	RW27-2D2-U017	
3/4	7.5/10	15...23	18	DLWM-B18■P66-RM67	CWB18	RW27-2D2-U023	1.270
3.7/5	-	15...23	23	DLWM-B25■P66-RM67	CWB25	RW27-2D2-U023	
-	-	22...32	25	DLWM-B25■P66-RM68	CWB25	RW27-2D2-U032	1.430
5.5/7.5	-	22...32	32	DLWM-B32■P66-RM68	CWB32	RW27-2D2-U032	
-	-	32...40	32	DLWM-B32■P66-RM69	CWB32	RW27-2D2-U040	1.430
-	-	32...40	38	DLWM-B38■P66-RM69	CWB38	RW27-2D2-U040	

Control voltage (add suffix code)



Degree of protection: 65 (IP65) or 66 (IP66)³⁾

Versions (add suffix code)

Control voltage 50/60 Hz ²⁾	220 V	230 V	240 V	400 V	415 V	460 V
■ Codes	D23	D24	D25	D34	D35	D38

Type of operation	Code
Start - Stop/Reset operation (standard)	P
Remote control (without buttons)	I
Stop/Reset operation (without ON button)	D
Hand/OFF/Auto operation (Hand = local control / Auto = remote control) + Start + Stop/Reset	B

Notes: 1) Some motors characteristics may vary according to each manufacturer;

2) Other voltages available;

3) IP66 only for size 05;

4) For enclosed starters with others configurations only under request, consult your WEG local distributor.

Accessories

Empty Enclosures

Illustrative pictures	Size	Degree of protection	Reference code	For use with	Weight (kg)
<p>Start + Stop/Reset operation</p>  <p>Design: 02 and 04 Design: 05</p>	02	IP65	EB02P-IP65	CW07 + RW17	0.200
	04	IP65	EB04CP-IP65	CWC07...16 + RW17	0.275
	05	IP66	EB05P-IP66	CWB9...38 + RW27-2D	0.210
	08	IP65	EB08P-IP65 ¹⁾	CWM50...80 + RW67-2D	1.305
<p>Remote control (without buttons) operation</p>  <p>Design: 02 and 04 Design: 05</p>	2	IP65	EB02I-IP65	CW07 + RW17	0.2
	4	IP65	EB04CI-IP65	CWC07...16 + RW17	0.275
	5	IP66	EB05I-IP66	CWB9...38 + RW27-2D	0.21
	8	IP65	EB08I-IP65 ¹⁾	CWM50...80 + RW67-2D	1.305
<p>Stop/Reset operation</p>  <p>Design: 02 and 04 Design: 05</p>	02	IP65	EB02D-IP65	CW07 + RW17	0.200
	04	IP65	EB04CD-IP65	CWC07...16 + RW17	0.275
	05	IP66	EB05D-IP66	CWB9...38 + RW27-2D	0.210
	08	IP65	EB08D-IP65 ¹⁾	CWM50...80 + RW67-2D	1.305
<p>Hand/OFF/Auto + Start + Stop/Reset operation</p>  <p>Design: 02 and 04 Design: 05</p>	02	IP52	EB02B-IP52	CW07 + RW17	0.210
	04	IP52	EB04CB-IP52	CWC07...16 + RW17	0.285
	05	IP52	EB05B-IP52	CWB9...38 + RW27-2D	0.210
	08	IP52	EB08P-IP52 ¹⁾	CWM50...80 + RW67-2D	1.305

Notes: 1) A metallic plate is supplied with this empty enclosed box.

Wiring Diagram

DLW (Three-Phase) Connected in Three-Phase Supply

Sizes: 02, 04 and 08

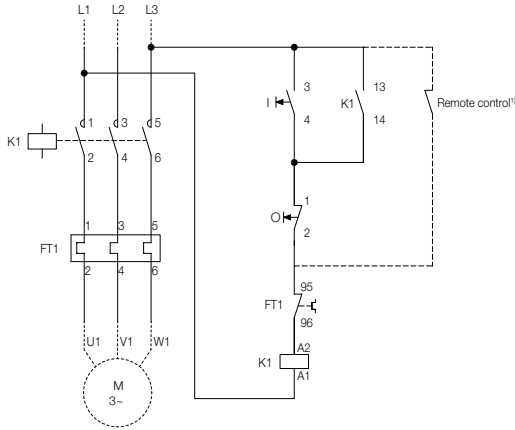

Size: 05

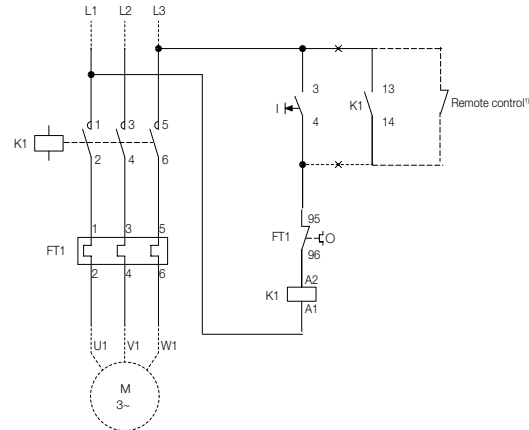
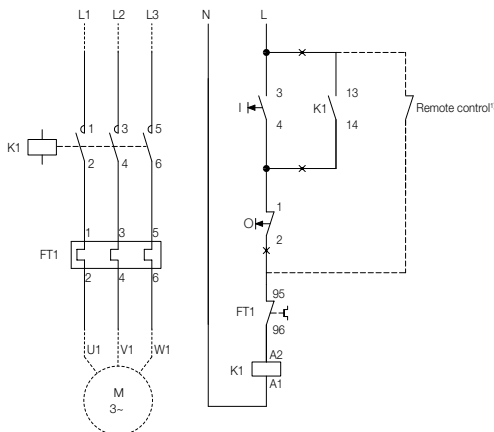

Figure 1 (phase to phase coil supply)

Sizes: 02, 04 and 08



Size: 05

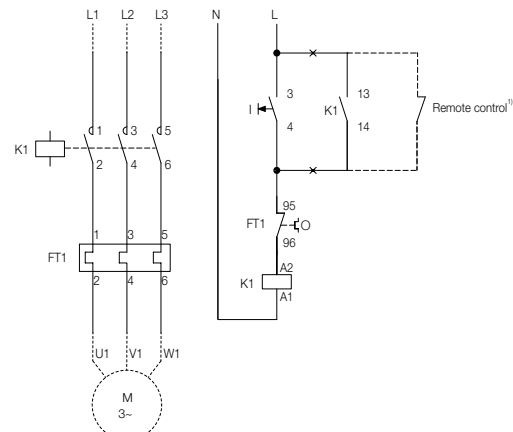

Figure 2 (control circuit connected through a separate coil supply)

--- Made by user

- Notes: 1) When using remote control, disconnect the circuit at the points marked with the "x" in figures 1 and 2 and connect the external devices (thermostat, pushbutton, etc.), as indicated with broken lines.
 2) When using 230 V, 400 V, 500 V, on the reference code, starters will be factory-connected, as per wiring diagrams of figure 1, that is, with phase to phase coil supply.
 3) When using 24 V, 48 V, 110 V, etc. on the reference code, starters will be factory-connected, as per wiring diagrams of figure 2, that is, with control circuit to be connected through a separate coil supply.

Wiring Diagram

DLWM (Single-Phase) Connected in Single-Phase Supply

Sizes: 02, 04 and 08

Size: 05

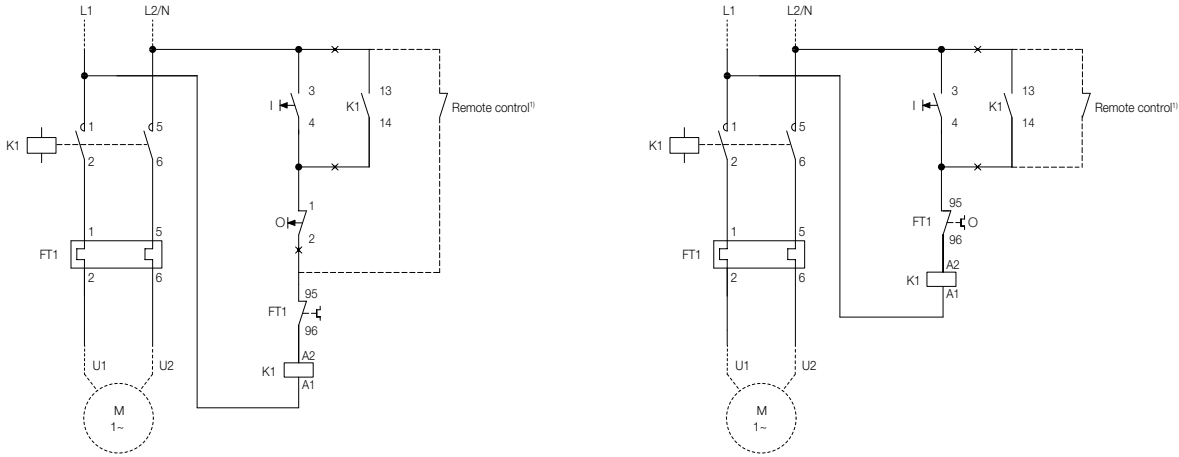

Figure 1 (phase to phase coil supply)

Sizes: 02, 04 and 08

Size: 05

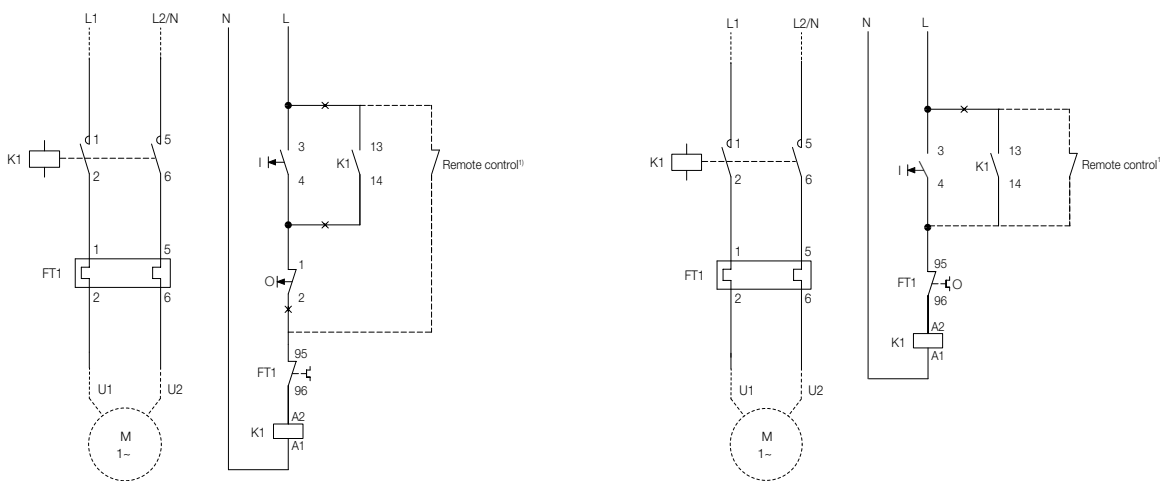
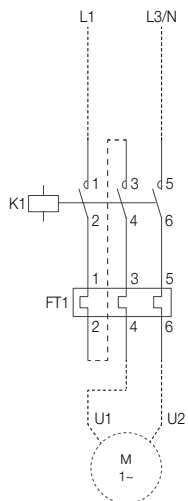

Figure 2 (control circuit connected through a separate coil supply)

Mandatory Connection to DLW (Three-Phase) Connected in Single-Phase Supply



--- Made by user

- Notes:
- 1) When using remote control, disconnect the circuit at the points marked with the "x" in figures 1 and 2 and connect the external devices (thermostat, pushbutton, etc.), as indicated with broken lines.
 - 2) When using 230 V, 400 V, 500 V, on the reference code, starters will be factory-connected, as per wiring diagrams of figure 1, that is, with phase to phase coil supply.
 - 3) When using 24 V, 48 V, 110 V, etc. on the reference code, starters will be factory-connected, as per wiring diagrams of figure 2, that is, with control circuit to be connected through a separate coil supply.

Dimensions (mm)

Sizes 02 and 04

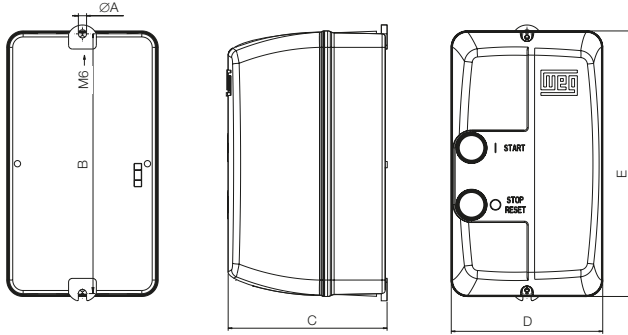

Size 05

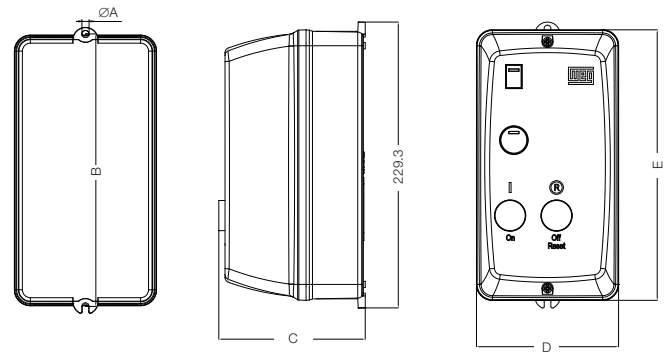

Frame 08

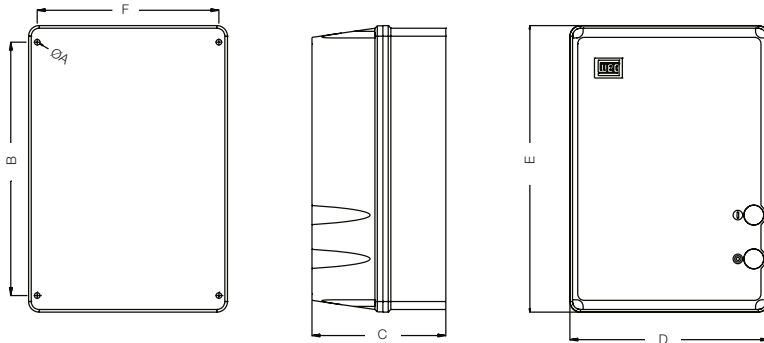

Mounting Installation

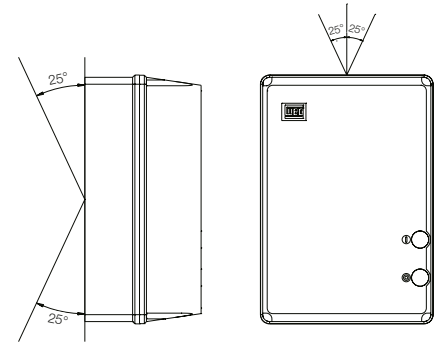

Enclosure

Size	02	04	05	08
ØA	4.5	4.5	5.5	5
B	150	180	219	245
C	98	111	117.5	143
D	90	105	114	180
E	155	185	217	280
F	-	-	-	166

Cable Knock-Outs

Size	02	04	05	08
Top	2xØPG16 or 2xØ20 mm		2xØPG13.5 or 2xØ20/25 mm	2xØPG21/29 or 2xØ25/32 mm
Button	2xØPG9 or 2xØ16 mm		2xØPG9 or 2xØ16 mm	-
Back	2xØPG9 or 2xØ16 mm		2xØPG9 or 2xØ16 mm	-

Technical Data

Standard	IEC/EN 60947
Operating temperature	-20 °C...55 °C
Storage temperature	-50 °C...80 °C
Degree of protection	IP65/66 ²⁾
Mechanical lifespan (operation)	1 x 10 ⁶
Electrical lifespan (operation)	1 x 10 ⁵
Maximum number of operation per hour	15 ¹⁾
Certifications	CE, ANCE, EAC, ICONTEC, IRAM
Thermoplastic enclosed material (cover and base)	V0 (fire retardant)
UV protection	Yes (inside or outside use)

Notes: 1) Limited by the thermal overload relay;
2) Only for size 05.

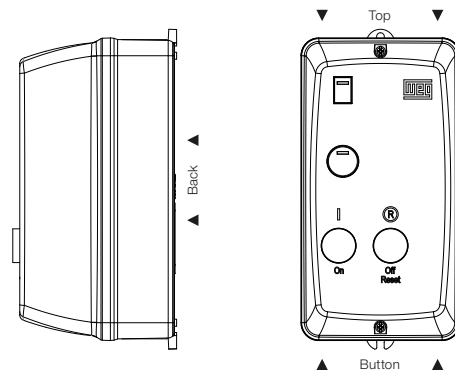

Global presence is essential. Understanding what you need, too.

Global Presence

With more than 30,000 employees worldwide, we are one of the largest electric motors, electronic equipments and systems manufacturers. We are constantly expanding our portfolio of products and services with expertise and market knowledge. We create integrated and customized solutions ranging from innovative products to complete after-sales service.

WEG's know-how guarantees our **Enclosed Starters** are the right choices for your application and business, assuring safety, efficiency and reliability.



Availability is to have a global support network



Partnership is to create solutions that suits your needs



Competitive edge is to unite technology and innovation



Know More

High performance and reliable products to improve your production process.



Excellence is to provide a whole solution in industrial automation that improves our customers productivity.

Visit: www.weg.net

[youtube.com/wegvideos](https://www.youtube.com/wegvideos)

WEG Worldwide Operations

ARGENTINA

San Francisco - Cordoba
Phone: +54 3564 421484
info-ar@weg.net

Cordoba - Cordoba
Phone: +54 351 4641366
weg-morbe@weg.com.ar

Buenos Aires
Phone: +54 11 42998000
ventas@pulverlux.com.ar

AUSTRALIA

Scoresby - Victoria
Phone: +61 3 97654600
info-au@weg.net

AUSTRIA

Markt Piesting - Wiener
Neustadt-Land
Phone: +43 2633 4040
watt@wattdrive.com

BELGIUM

Nivelles - Belgium
Phone: +32 67 888420
info-be@weg.net

BRAZIL

Jaraguá do Sul - Santa Catarina
Phone: +55 47 32764000
info-br@weg.net

CHILE

La Reina - Santiago
Phone: +56 2 27848900
info-cl@weg.net

CHINA

Nantong - Jiangsu
Phone: +86 513 85989333
info-cn@weg.net

Changzhou - Jiangsu
Phone: +86 519 88067692
info-cn@weg.net

COLOMBIA

San Cayetano - Bogota
Phone: +57 1 4160166
info-co@weg.net

ECUADOR

El Batan - Quito
Phone: +593 2 5144339
ceccato@weg.net

FRANCE

Saint-Quentin-Fallavier - Isère
Phone: +33 4 74991135
info-fr@weg.net

GERMANY

Türnich - Kerpen
Phone: +49 2237 92910
info-de@weg.net

Balingen - Baden-Württemberg
Phone: +49 7433 90410
info@weg-antriebe.de

Homburg (Efze) - Hesse
Phone: +49 5681 99520
info@akh-antriebstechnik.de

GHANA

Accra
Phone: +233 30 2766490
info@zestghana.com.gh

INDIA

Bangalore - Karnataka
Phone: +91 80 41282007
info-in@weg.net

Hosur - Tamil Nadu
Phone: +91 4344 301577
info-in@weg.net

ITALY

Cinisello Balsamo - Milano
Phone: +39 2 61293535
info-it@weg.net

JAPAN

Yokohama - Kanagawa
Phone: +81 45 5503030
info-jp@weg.net

MALAYSIA

Shah Alam - Selangor
Phone: +60 3 78591626
info@wattdrive.com.my

MEXICO

Huehuetoca - Mexico
Phone: +52 55 53214275
info-mx@weg.net

Tizayuca - Hidalgo
Phone: +52 77 97963790

NETHERLANDS

Oldenzaal - Overijssel
Phone: +31 541 571080
info-nl@weg.net

PERU

La Victoria - Lima
Phone: +51 1 2097600
info-pe@weg.net

PORTUGAL

Maia - Porto
Phone: +351 22 9477700
info-pt@weg.net

RUSSIA and CIS

Saint Petersburg
Phone: +7 812 363 2172
sales-wes@weg.net

SOUTH AFRICA

Johannesburg
Phone: +27 11 7236000
info@zest.co.za

SPAIN

Coslada - Madrid
Phone: +34 91 6553008
wegiberia@wegiberia.es

SINGAPORE

Singapore
Phone: +65 68589081
info-sg@weg.net

Singapore
Phone: +65 68622220
watteuro@watteuro.com.sg

SCANDINAVIA

Mölnlycke - Sweden
Phone: +46 31 888000
info-se@weg.net

UK

Redditch - Worcestershire
Phone: +44 1527 513800
info-uk@weg.net

UNITED ARAB EMIRATES

Jebel Ali - Dubai
Phone: +971 4 8130800
info-ae@weg.net

USA

Duluth - Georgia
Phone: +1 678 2492000
info-us@weg.net

Minneapolis - Minnesota
Phone: +1 612 3788000

VENEZUELA

Valencia - Carabobo
Phone: +58 241 8210582
info-ve@weg.net

For those countries where there is not a WEG own operation, find our local distributor at www.weg.net.



WEG Group - Automation Business Unit
Jaraguá do Sul - SC - Brazil
Phone: +55 47 3276 4000
automacao@weg.net
www.weg.net

